

Section G2: PROTECTION AND CONTROL REQUIREMENTS FOR TRANSMISSION GENERATION ENTITIES

Purpose

This section specifies the requirements for protective relays and control devices for Generation Entities interconnecting to the PG&E Power System.

Applicability

The applicable protective standards of this section apply to all Generators interconnecting to PG&E's Transmission Power System at 50 kV or above. Interconnections to PG&E's Transmission Power System below 50 kV are governed by CPUC Rule No. 21 - "Generating Facility Interconnections". These standards govern the design, construction, inspection and testing of protective devices, have been developed by PG&E to be consistent with Applicable Regional Reliability Criteria¹ and to include appropriate CAISO consultation. The CAISO, in consultation with PG&E, may designate certain new or existing protective devices as CAISO Grid Critical Protective Systems. Such systems have special CAISO requirements, e.g., for installation and maintenance, as described in the [CAISO Tariff](#) Section 25 and the Transmission Control Agreement between PG&E and the CAISO, Section 8.

In the future, the CAISO may develop its own standards or requirements applicable to certain interconnections, and also will review and comment on interconnection requests to the CAISO Controlled Grid. Refer to the Introduction of this handbook.

In addition, for Generation Entities connecting directly to a Third Party: A third party must coordinate with the CAISO, PG&E (as the Transmission Owner), and the Generation Entity, as needed, to ensure that any CAISO Controlled Grid Critical Protective Systems, including relay systems, are installed and maintained in order to function on a coordinated and complementary basis with the protective systems of the Generation Entity and the PG&E Power System, in accordance with the [CAISO Tariff](#) Section 4 and the CAISO-UDC Agreement, both available on the [CAISO website](#).

When interconnecting to the Bulk Energy System: When connecting to the Bulk Electric System (BES), as defined by NERC then, all protective systems, including the station dc supply (e.g. batteries) associated with protective functions, must follow all NERC requirements. There may be additional requirements as determined by PG&E to ensure the integrity of the PG&E BES is maintained.

Point of Interconnection (POI) Limitations on the PG&E Grid: As industry rapidly changes from "centralized" generation to "distributed" generation, it has become necessary for PG&E to provide POI limitations. Effective January 1, 2022, for all new

¹ See Glossary for more information. NERC reliability standards for transmission voltage levels of 100kV and above require the use of two separate voltage and current sources to be connected to the primary and alternate line protective relays respectively. Conformance to WECC and NERC standards are required for interconnections above 100kV voltage levels.

applications for interconnection with the PG&E system, there are three POI limitations: 1) FERC 1000 restrictions 2) fault duty limitations and 3) station proximity limitations.

1. FERC 1000

For customers applying for interconnection via the FERC 1000 process, be aware that third parties must not submit proposals with POIs inside a PG&E substation.

2. Fault Duty Limitations

Certain substation busses have reached the ultimate fault duty limitation of 63 kA and no longer have physical space for additional reactors to correct the fault duty. The substation busses shown in Table G2 can no longer accommodate new POI requests. Note: The 500kV system is operated at nominal 525kV voltage level.

Table G2 – List of Substation Busses That Cannot Accept New POI’s

Midway 500 kV	Tesla 500 kV
Midway 230 kV	Tesla 230 kV
Midway 115 kV	Tesla 115 kV
Metcalf 115 kV	Newark 230 kV
Metcalf 230 kV	Newark 115 kV
Pittsburg 230 kV	Pittsburg 115 kV

3. Proximity Limitations

Certain situations, based on case-by-case, may require PG&E to stipulate a switching station location based on asset utilization of near-by switching stations, long-term maintenance and operating costs, overlapping cluster requests and good engineering judgement.

4. Space Limitations

Certain substation locations have been fully built out and no longer have the physical space in the surrounding area to accommodate substation expansions. The substation locations shown in table G2-A can no longer accommodate new POI requests.

Table G2-A – List of Substation Busses That Cannot Accept New POI’s based on Space Limitations

Tranquillity 230 kV	Gates 500 kV
Pittsburg 230 kV	

Rules on Tapping Transmission Lines - Effective January 1, 2016, tapping a transmission line, on PG&E owned lines, for new load and generation interconnections is not permitted on the PG&E system for 100 kV and above. The required method of interconnecting new load/generation is via a new or existing substation. If a new transition switching station is required in-lieu of a tap, on a PG&E owned line, then the new station must be owned, operated and maintained by PG&E. PG&E must approve the transition station, bus configuration (e.g. BAAH or BAAH operated as a ring).

If the transition station is on the customer's property, then, know that, grid or loop flow is not allowed through a 3rd party facility.

Effective January 1, 2019, tapping 3rd party transmission lines owned, operated and maintained by a 3rd party are restricted, and exceptions may or may not be allowed upon review of standby load agreements being served through non-PG&E facilities and installation of PG&E interconnection requirements required to safely and reliably interconnect the project.

The Table G2B summarizes the rules for tapping transmission lines for load or generation.

Table G2-B

RULES FOR TAPPING TRANSMISSION LINES

Above 100 kV	Below 100 kV
Tapping not permitted. All new connections for above 100 kV must be to a new or existing substation.	Interconnections are preferred to new or existing substations. Exceptions are allowed on a restricted basis with PG&E’s written approval as determined by PG&E standards.
Existing taps are “grandfathered” in	Existing taps are “grandfathered” in

It is the Interconnection Customer’s responsibility to permit, engineer, build, and own the Gen Tie Line from the Customer’s Interconnection Substation to the PG&E POI Substation Property.

G2.1. Protective Relay Requirements

The primary safety requirement is to disconnect interconnection facilities immediately when a fault is detected, to minimize potential loss of life and property.

The protection equipment for a generation entity must protect against faults within that facility and faults on the PG&E Power System. A generation facility must also trip off-line (disconnect from the PG&E Power System automatically) when PG&E’s power is disconnected from the line into which the unit is generating.

PG&E line-protective equipment must perform one of the following;

- 1) Automatically clear a fault and restore power
- 2) Rapidly isolate only the faulted section so that the minimum number of customers are affected by any outage.

PG&E standardizes protection requirements as much as possible, however there are many system variables impacting protection requirements such as generator size and type, number of generators, fault duties, line characteristics (e.g. voltage, impedance and ampacity) and pre-existing protection schemes. Identical generators at different locations may have widely varying protection requirements and costs. For example, high-speed fault clearing may or may not be required to minimize equipment damage and potential impact to system stability. Appendix R, “Protective Relay requirements and Approvals” and Appendix S, “Protection Alternatives for Various Generator Configurations” provide more protection details.

PG&E's protection requirements are designed and intended to protect the PG&E Power System only. As a general rule, neither party should depend on the other for the protection of its own equipment.

Additional protective relays are typically needed to adequately protect the Generation Entity's facility. It is the Generation Entity's responsibility to protect its own system and equipment from faults or interruptions originating on both PG&E's side and the Generation Entity's side of the Interconnection. The Generation Entity's System Protection Facilities shall be designed, operated, and maintained to isolate any fault or abnormality that would adversely affect the PG&E Power System, or the systems of other entities connected to the PG&E Power System.

The Generation Facility shall, at its expense, install, operate, and maintain system protection facilities in accordance with applicable CAISO, WECC and NERC requirements and in accordance with design and application requirements of this Handbook.

The protective relays used in isolating the Generation Facility from the PG&E Power System at the Point of Interconnection must be:

- 1) PG&E-approved devices
 - a. The required types of protective devices are listed on Tables [G2-3](#) and [G2-4](#). Typical protection and metering installations are shown on Figures G1-1 and G1-2 in [Section G1](#).
- 2) Set to coordinate with the protective relays at the PG&E line breaker terminals for the line on which the Generation Facility is connected.
- 3) The exact type and style of the protective devices may be imposed on the Generation Entity based on the proposed station configuration or the type of interrupting device closest to the point of common coupling to PG&E's facility.

Note: If additional protective equipment is required, at the Generation Entity's cost, PG&E will coordinate with the Generation Entity or its representatives.
- 4) Line protection schemes protecting 525kV-PG&E owned transmission lines will be specified by PG&E.

For any given fault, applicable relay targets must be provided.

Do not change relay settings without PG&E's written approval.

Submittals: Table G2-1 shows the documents that must be submitted for review before any agreements are executed.

Table G2-1
Document Submittals

No.	Drawing or Document Required	Timing
1.	Single Line Diagram ²	Mandatory (PG&E must approve prior to relay and major equipment purchase)
2.	Single Line Meter and Relay Diagrams ²	Mandatory (PG&E must approve prior to relay and major equipment purchase)
3.	3-Line AC or schematic drawings	Mandatory prior to pre-parallel, (advise PG&E review prior to fabricating relay panels)
4.	DC schematics or tripping schemes for all PG&E required relays	Mandatory prior to pre-parallel, (advise PG&E review prior to fabricating relay panels)
5	Battery Form AT-1 from Appendix F	Mandatory prior to pre-parallel (PG&E must approve the station battery)
6	Modeling information (Aspen, PSCAD, RTDS)	Mandatory, equipment information is required to develop and run simulations. (RTDS models (PSCAD will not suffice) are required for all 500kV interconnections.

Leased Circuits: It is critical to the project schedule that the required leased circuits are ordered many months in advance of the operational date. In Appendix F the timeframes are provided for different types of circuits and services. These are approximate lead times since each facility will have to be evaluated by the telephone company to determine the availability of adequate cable pair facilities for the required service. If the requisite cable plant is not available, the project timeline may be extended 6 to 12 months. The required leased circuits must be in place before a company may generate electricity into the PG&E power grid³.

² Refer to Appendix F for recommendations and requirements associated with pilot protection.

³ Communication-assisted protection tests include end-to-end satellite testing of the protection and communication between the interconnected terminals as a system. See Appendix F for more information.

Test Reports: The Generation Entity must provide PG&E with test reports ([Form G2-2](#)) for the particular types of protective devices applied as outlined in Tables [G2-3](#) and [G2-4](#) **30 days** before PG&E will allow the facility to parallel and every six years after that. Where tele-protection is utilized, the communication circuits must be tested, and the scheme operation functionally verified prior to release for commercial operation.

G2.2. Reliability and Redundancy

The Generation Entity shall design the protection system with enough redundancy that the failure of any one component will still permit the Generation Entity's facility to be isolated from the PG&E Power System under a fault condition. Multi-function three-phase protective relays must have redundant relay(s) for back-up. Each redundant relay must have a separate current and voltage source. This can be accomplished via redundant CT's and a dual wound potential device where each winding is connected to its perspective relay. For generation relay voltage inputs a single voltage source may be used for both relays. An example of relays requiring redundancy would be the intertie breaker and the main customer transformer protection. The redundant relay can be from the same manufacture and model number. Inverter based generation < 1MW that is UL 1741 certified may use on board voltage and frequency elements that meet PRC 24-2 setting requirements without an external relay. Inverter based generation > 1MW must have redundant voltage and frequency devices with settings meeting PRC 24-2 requirements. PG&E strongly recommends against using fuses for protection of DC control and protection circuits, since they could fail open without indication resulting in disabling of protection and controls including breaker tripping. If fuses are used in trip circuits, trip coil monitoring and alarming must be used.

G2.2.2 500kV Systems

The "500kV class system" is operated at 525kV with a typical operating range of 525 – 540 kV.

- All interconnections must adhere to the existing operating modes of the 500kV system (one example is single pole tripping, single pole vulnerability).
- Interconnection to the 500kV system requires dual vendor and dual algorithm relays for all protection systems that are protecting PG&E owned 500kV system equipment (includes the 500kV lines, 500kV busses, and 500kV high side transformer protection relays as applicable).
- Interconnection entity must comply with the outdoor and indoor criteria for Single Component failure minimization.
- Breaker tripping must employ dual trip coils energized from all of the protection relays that are protecting the element, including the breaker failure protection.
- All relays protecting the 500kV system require a relay failure alarm contact (contact closed when relay de-energized) to be wired for remote 24/7 monitoring
- All 500kV line relays to match exact type and firmware specified by PG&E.
- For all interconnections to existing 500kV lines, relay cut out (RCO) switches or equivalent are required. All protection relays that trip 500kV breakers require separate RCO contact (independent from the relay) that is hard wired

- in series with the relay output contacts used for breaker tripping to both breaker trip coils and breaker failure initiation.
- Maintenance switches for breakers and lines are required for all RAS schemes which are independent of the relays being used to protect the element (ex. The breaker maintenance switch equivalent cannot be contained within the breaker failure relay).

Other Requirements:

The Generation Entity must install a disconnect device or switch with generation interrupting capability at the Point of Interconnection (POI).

Generally, fault-interrupting equipment should be located as close to the interconnection point as possible - typically within one span of overhead line or 200 feet of unspliced underground cable.

Breaker failure may be required in some instances. In those instances, PG&E will evaluate the breaker failure scheme and tripping modes. Breaker failure is always required on the 500kV system and must be operational and in service for the breaker to remained closed and energized.

G2.3. Relay Grades

Only utility grade relays can be used for interconnection protection. This requirement must include the protective and tripping relays used to trip the breaker separating the facility from the PG&E system.

Utility grade relays have much higher reliability and accuracy than industrial grade relays (see Tables [G2-7](#) and [G2-8](#)).

- All utility grade relays must include manually resettable relay targets.
- All relays must have 5A nominal AC input current.
- All utility grade relay power supplies must be powered by station battery DC voltage, and the battery system should include a DC undervoltage detection device and alarm. See Section G2.20 and [Appendix T](#) (Battery Requirements for Interconnection to PG&E System)

NOTE

Monitoring of the DC battery voltage by a separate voltage relay or through a charger that provides a critical alarm to a 24/7/365 monitoring system is required per NERC. For installations that are too small to have SCADA, then an annunciated alarm with strobe light with audible alarm can be substituted. PG&E's written approval is required for any other alarm notification methods.

All proposed relay specifications must be submitted to PG&E for approval prior to ordering. Line and generation protection elements are specified in Tables [G2-3](#) and [G2-4](#). Line and Generation protection relays must come from PG&E's approved list (Tables [G2-7](#) and [G2-8](#)) or the Generation Entity can have testing performed to qualify relays in accordance with the [Appendix R](#) - "Protective Relay Requirements and Approvals". Any required qualified tests shall be performed at the Generation Entity's expense and prior to PG&E approval of the relay for interconnection use. PG&E approval does not indicate the quality or reliability of a product or service, and endorsements or warranties shall not be implied. If the entity wants to use a relay not on the PG&E approved list (Tables [G2-7](#) and [G2-8](#)) the entity should allow additional time for testing and PG&E's written approval.

G2.4. Line Protection

Line-protection relays must coordinate with the protective relays at the PG&E breakers for the line on which the generating facility is connected. The typical protective zone is a two-terminal line section with a breaker on each end. In the simplest case of a load on a radial line, current can flow in one direction only, so protective relays need to be coordinated in one direction and do not need directional elements. However, on the typical transmission system, where current may flow in either direction depending on system conditions, relays must be directional. Also, the complexity and the required number of protective devices increase dramatically as the number of terminals increase in each protective zone. With two terminals in a protective zone, there are two paths of current flow. With three terminals there are six paths of current flow, and so on. For this reason, three terminals are discouraged and, in most cases, will not be allowed on the Bulk Electric System (BES) system.

In coordinating a multi-terminal scheme, or short generation tie lines PG&E may require installation of a communication aided transmission line relaying scheme. Common schemes of this type are Permissive Overreaching Transfer Trip (POTT) schemes or Line Current Differential (LCD) schemes. In these types of schemes the transmission line protective relay at the Generation Entity's substation site will be required to be of the same manufacture and firmware as the PG&E relays for proper operation of the scheme. Because this line relay participates in a scheme to protect the PG&E transmission system, PG&E must ensure the maintenance, testing and reliability of this particular type of relay.

The relays must be connected to the breaker CTs in such a way that zones of protection overlap. The line protection schemes must be able to distinguish between generation, inrush and fault currents. Multiple terminal lines become even more complex to protect. Existing relay schemes may have to be reset, replaced, or augmented with additional relays at the Generation Entity's expense, to coordinate with the Generation Entity's new facility.

The PG&E required relays must be located so that a fault on any phase of the PG&E interconnected line(s) shall be detected.

If **transfer trip or communication aided relaying scheme** is required by PG&E, the Generation Entity shall provide all required communication circuits at its expense. A

communication circuit may be a leased line from the telephone company, a dedicated cable, microwave, or a fiber optic circuit and shall be designed with sufficient levels of monitoring of critical communication channels and associated equipment. PG&E will determine the appropriate communication medium to be used on a case-by-case basis. The leased phone line or dedicated communication network must have high-voltage protection equipment on the entrance cable so the transfer trip equipment will operate properly during fault conditions. (Refer to Appendix F for a detailed description of protection requirements and associated transfer trip equipment and communications circuits monitoring.)

Table G2-2

Repair Times

Purpose of Protection (1)	If Redundant or Has Back-up Protection (2)	If <u>not</u> Redundant or with No Back-up Protection
Transfer Trip	Type B – OK to remain online, start repairs within 24 hours and repair in 7 days or separate	Type A – Must separate from system and repair prior to return to service
Communication Aided Schemes	Repair per normal processes	Repair or separate in 7 days
Protective Relays	Repair in 7 days or separate	Separate and repair prior to return to service
RAS (3)	Repair in 7 days or separate	Separate and repair prior to return to service
EMS/SCADA	Begin repair within 30 days	Complete repair within 30 days

Notes:

1. This includes all associated equipment in the scheme and especially the communications path.
2. If the backup fails, separate immediately and stay offline until repair are complete.
3. For RAS, refer to individual Interconnection Agreement and/or PG&E Grid Control Center for exceptions.

The PG&E transmission system and the distribution network system are designed for high reliability by having multiple sources and paths to supply customers. Due to the multiple sources and paths, more complex protection schemes are required to properly detect and isolate the faults. The addition of any new generation facility to the PG&E

Power System or continued operation of an existing generator must not degrade the existing protection and control schemes or cause existing PG&E customers to suffer lower levels of safety and/or reliability (see [Electric Rule 2](#)).

Many portions of the PG&E Power System have provisions for an alternate feed. In some locations, the generation cannot be allowed on line while being fed from an alternate source due to inadequate protection. Whenever possible, the Generation Entity will be given the option of paying for any required upgrades so that they can stay on-line while transferred to the alternate source or not paying for upgrades and accepting shutdowns when transferred to the alternate source.

Table [G2-3](#) lists the minimum protection that PG&E typically uses on its own installations. Higher voltage interconnections require additional protection due to the greater potential for adverse impact to system stability, and the greater number of customers who would be affected. Special cases such as distribution-level network interconnections, if acceptable, may have additional requirements. The acceptability and additional requirements of these interconnection proposals shall be determined by PG&E on a case-by-case basis.

Table G2-3

Line Protection Devices^{4 5 6 7}

Line Protection Device	Device ³ Number	34.5kV or less	44kV, 60kV or 70kV	115kV	230kV
Phase Overcurrent (Radial systems)	50/51	X	X		
Ground Overcurrent (Radial systems)	50/51N	X	X		
Phase Directional Overcurrent	67		X ¹	X	
Ground Directional Overcurrent or Transformer Neutral	67N 50/51N		X ¹	X	X
Distance Relay Zone 1 (phase and ground elements where applicable)	21Z1 / 21 Z1N		X ¹	X ¹	X
Distance Relay Zone 2 (phase and ground elements where applicable)	21Z2 / 21 Z2N		X ¹	X ¹	X
Distance Relay Carrier	21Z2C			X ¹	X
Ground Directional Overcurrent Carrier	67NC			X ¹	X
Distance Relay Carrier Block	21Z3C			X ¹	X
Pilot Wire, Current differential, and Phase Comparison	87L/78			X ¹	X
Permissive Overreaching Transfer Trip (POTT) or Hybrid	21/67T			X ¹	X
Direct Transfer Trip	TT	X ²	X ²	X ²	X ²

Notes:

1. May be required on transmission or distribution interconnections depending on local circuit configurations, as determined by PG&E.

2. Transfer trip may be required on transmission-level or distribution-level interconnections depending on PG&E circuit configuration and loading, as determined by PG&E. Typically, transfer trip shall be required if PG&E determines that a generation facility cannot detect and trip on PG&E end-of-line faults within an acceptable time frame, or if the generation facility may be capable of keeping a PG&E line energized with the PG&E source disconnected. It should be noted for most Inverter Based generating facilities line phase fault detection is not feasible therefore DTT will be required (Appendix F). For NEM inverter based generation $\leq 10\text{MW}$ with UL 1741SA/SB active anti-islanding enable, DTT may be waived under certain conditions. This will be evaluated on a case per case basis.
3. Refer to Table G2-6 for device number definitions and functions.
4. Line protection application is a function of the power system parameters and equivalent sources to which equipment are interconnected given the rating of the equipment being installed for interconnection purposes.
5. All relays must have 5A nominal AC input current.
6. For microprocessor relays, with directional elements that block operation on Loss of Potential (LOP), then another protection element must be enabled. PG&E's written approval is required.
7. 500kV Relays will be reviewed and specified by PG&E.

G2.5. Generator Protection and Control

Single-phase generators must be connected in multiple units so that an equal amount of generation capacity is applied to each phase of a three-phase circuit.

All synchronous, induction and single-phase generators shall comply with the latest ANSI Standards C50.10 and C50.13, dealing with waveform and telephone interference.

Synchronous generators of any size will require: a) synchronizing relays, synch check, or auto synchronizer (Device No. 25) to supervise generator breaker closing, and b) reclose blocking at the PG&E side of the line to which the generator is connected (applies to substation breaker/recloser and line reclosers). For Inverter Based generation systems they shall comply with IEEE Std. 519 for dealing with power quality. Generally Inverter Based generation systems cannot operate standalone and do not require auto-synchronizing or synch check functions, however each installation must be evaluated by PG&E on a case by case basis.

The generator protection equipment listed in Table [G2-4](#), in addition to those listed in Table [G2-3](#), is required to permit safe and reliable parallel operation of the Generation Entity's equipment with the PG&E Power System. Additional generator protection requirements shall be determined by PG&E on a case-by-case basis.

Table G2-4
Generator Protection Devices

Generator Protection Device	Device ¹ Number	40 kW or Less	41 kW to 400 kW	401 kW and Larger
Phase Overcurrent	50/51	X ^{2,9}	X ^{2,9}	
Overvoltage	59	X	X	X
Undervoltage	27	X ³	X	X
Overfrequency	81O	X	X	X
Underfrequency	81U	X	X	X
Ground Fault Sensing Scheme (Utility Grade)	51N		X ⁴	X ⁴
Overcurrent With Voltage Restraint/Voltage Control or Impedance Relay	51V ^{8,10} 21 ^{8,10}		X ^{5,9}	X ⁹
Reverse Power Relay (No Sale)	32 ¹⁰	X ⁶	X ⁶	X ⁶

Notes:

1. Refer to Table [G2-6](#) for device number definitions and functions.
2. Overcurrent protection must be able to detect a line-end fault condition. A phase instantaneous overcurrent relay that can see a line fault under sub-transient conditions is required. This is not required if a 51V relay is used.
3. For generators 40 kW or less, the undervoltage requirement can be met by the contactor undervoltage release.
4. For induction generators aggregating less than 100 kW, ground fault detection is not required. For certified non-islanding inverters aggregating less than 1MW ground detection is not required. Ground fault detection is required for non-certified induction generators of 100kW or larger capacity. For synchronous generators aggregating over 40 kW, and induction generators aggregating over 100kv, ground fault detection is required.
5. A group of generators, each less than 400 kW but whose aggregate capacity is 400 kW or greater, must have an impedance relay or an overcurrent relay with voltage restraint located on each generator greater than 100 kW. Due to the limited fault contribution of Inverter based generating systems the 51V and 21 requirements are waived, DTT will be utilized to trip the PV offline.
6. For “No Sale” generator installations, under the proper system conditions, a ,very sensitive reverse power relay that can operate on a per phase basis , along with the dedicated transformer may be used in lieu of ground fault protection. The relays shall be set to pick-up on transformer magnetizing current and trip the main breaker within 0.5 second.
7. All relays must have 5A nominal AC input current.
8. Due to the limited fault contribution of inverter based generating systems the 51V and 21 requirements are waived, DTT will be utilized to trip the PV offline. For NEM inverter-based generation \leq 10MW with UL 1741SA/SB active anti-

islanding enable, DTT may be waived under certain conditions. This will be evaluated on a case per case basis.

9. For certified non-islanding inverters aggregating less than 1MW with active anti-islanding enabled the 51V and 21 requirements and DTT requirements are waived.
10. For microprocessor relays, with directional elements that block operation on Loss of Potential (LOP), then another protection element must be enabled to provide PG&E equipment protection.. PG&E’s written approval is required.

The following paragraphs describe the required protective and control devices for generators:

G2.5.1. Phase Overcurrent

See Table [G2-6](#) (Device 50/51) for definition and function.

G2.5.2. Over/Undervoltage Relay

Over/Undervoltage relay protection is used for generator and customers equipment protection in the event that the generator is carrying load that has become isolated from the PG&E Power System. In severe cases, it may operate for un-cleared faults. The voltage thresholds listed in [Table G2-9](#) for the “No Trip Zone” are based on NERC PRC-24-2 to maintain generation on-line during voltage disturbances. Actual relay settings are to be made by the generator owner based on their protection requirements while satisfying the listed limits at the POI.

G2.5.3. Over/Underfrequency Relay

This is used for generator/turbine protection and backup protection, the “No Trip Zone” is listed in [Table G2-9](#).

Generator underfrequency relay settings are coordinated with other utilities in the Western Electricity Coordinating Council (WECC) to maintain generation on line during system disturbances. The frequency settings must not allow less stringent operation of the generation facility than specified in the WECC Off Nominal Frequency Requirements.

G2.5.4. Grounding and Ground Fault Sensing Scheme

G2.5.4.1. General:

The ground fault sensing scheme detects PG&E Power System ground faults and trips the generator breaker or the generating facility’s main circuit breaker, thus preventing the Generation Entity's generator from continuously contributing to a ground fault. This scheme must be able to detect faults between the PG&E system side of the dedicated transformer and the end of PG&E's line. The following transformer connections, along

with appropriate relaying equipment, are commonly used to detect system ground faults and prevent transmission overvoltage during ground faults:

- System side - grounded wye; generator side - delta
- System side - grounded wye; generator side - wye; tertiary - delta

G2.5.4.2. Ground Grid Requirements

Customer Owned Facilities - For customer or third party owned facilities adjoining or near-by PG&E facilities, the ground grid requirements are slightly different depending on whether or not, there are any metal connections (e.g. electrical, communication. etc.) between a PG&E ground grid and a customer's ground grid.

If the customer facilities is, in any way, not connected to the PG&E ground grid or neutral system, then the customer is solely responsible for the design and safety limits of their grounding system facilities and must:

- Follow IEEE Std. 80, "Guide for Safety in AC Substation Grounding", for step, touch, and ground potential and,
- If the ground grid resistance is greater than 1 ohm, then include PG&E in evaluating the ground grid and fault study calculations.

If a customer facility is connected to a PG&E-owned or would be PG&E-owned ground grid, then PG&E must be involved with the ground grid design and approval.

See L3, "Substation Design", Section 7- "Switches" and G2-7 below for more information on the POI disconnect switch on customer owned facilities. In addition, switch and switch platform grounding must be per Engineering Design Drawing 067910 (see Appendix D).

PG&E Owned – If the facilities will be designed and built by others and deeded to PG&E to own and operate then, the ground grid must be built per PG&E standards.

Ground Fault Detection -Transformers connected to the transmission system at 60 kV and higher must have a grounded wye connection on the system side, and a ground current sensing scheme must be used to detect ground faults on the PG&E Power System.

Special Case for Load Entities Adding Generation: For load entities adding generation to their facility where the existing transformer is delta connected on the high voltage side, an over voltage evaluation must be performed to ensure the facility doesn't create over voltage conditions. Studies and mitigations to prevent over voltage are at the cost of the facility owners. PG&E's written approval is required.

G2.5.5. Overcurrent Relay with Voltage Restraint/Voltage Control or Impedance Relay

These relays are used to detect multi-phase faults and initiate a generator circuit breaker trip. The relays must be located on the individual generator feeder. A group of generators aggregating over 400 kW must have an impedance relay or an overcurrent relay with voltage restraint located on each generator greater than 100 kW. Generators equal to or greater than 400 kW must have an impedance relay or an overcurrent relay with voltage restraint. As determined by PG&E protection studies, an overcurrent relay with voltage control may also be acceptable if it can be set to adequately detect end-of-line faults. If the generator step-up transformer is connected wye-delta or delta-wye, a delta-wye or wye-delta auxiliary potential transformer is required on the potential circuits to the voltage restraint or voltage-controlled overcurrent relay for phase shift correction based on the relay design and operating principal. The Generation Entity should contact the PG&E representative for assistance in the proper connection of the auxiliary transformers.

Due to the limited fault contribution of Inverter based generating systems the above 51V requirement is waived.

G2.5.6. Reverse Power Relay

See [Table G2-6](#) (Device #32) for definition and function.

G2.6. Dedicated Transformer

A dedicated transformer is required to step-up the generator voltage to the interconnection level and isolate the Generation Entity from other customers.

The impedance of a dedicated transformer limits fault currents on the generator bus from the PG&E Power System and limits fault currents on the PG&E Power System from the generator. Hence, it reduces the potential damage to both parties due to faults. It also must have a delta winding to reduce the generator harmonics entering the PG&E Power System. The delta winding will also reduce the PG&E Power System harmonics entering the generation facility.

A high-side fault-interrupting device is required for transformer protection. A three-phase circuit breaker is recommended.

Lightning arrestors, if the Generation Entity chooses to install them, must be installed between the transformer and the fault-interrupting devices and be encompassed by the generator's relay protection zone.

G2.7. Manual Disconnect Switch

G2.7.1. General

When tapping a transmission line below 100 kV, a manual disconnect switch on the tap line (Tap Line Switch) is required for a generation facility. Two additional

Line Selector Switches, one on each side of the tap, may also be required to ensure better service and operating flexibility.

A PG&E-operated disconnect device must be provided as a means of electrically isolating the PG&E Power System from the generator. This device shall be used to establish visually open working clearance for maintenance and repair work in accordance with PG&E safety rules and practices. A disconnect device must be located at all points of interconnection with PG&E. The disconnect switch must be a gang-operated, three-pole lockable switch.

If the switch is to be located on the PG&E side of the interconnection point, PG&E will install the switch at the Generation Entity's expense. If the device is to be located on the entity's side, it must be furnished, installed, owned and operated by the Generation Entity. All switch devices must be approved by PG&E. PG&E personnel shall inspect and approve the installation before parallel operation is permitted. If the disconnect device is in the Generation Entity's substation, it should be located on the substation dead-end structure and must have a PG&E-approved operating platform.

The disconnect device must not be used to make or break parallels between the PG&E Power System and the generator(s). The customer owned device enclosure and operating handle (when present) shall be kept locked at all times with PG&E padlocks.

The disconnect device shall be physically located for ease of access and visibility to PG&E personnel. When installed on the Generation Entity's side of the interconnection, the device shall normally be installed close to the metering. The PG&E-operated disconnect shall be identified with a PG&E designated switch number plate.

Metering is normally on the high-side of the Generation Entity's step-up transformers. Between the metering units and the circuit breaker, a second disconnect device is required; it shall not have a PG&E lock and may be operated by the Generation Entity.

G2.7.2. Operation of Switch

If PG&E deems a switch unsafe to operate, then the Generation Entity's representative must operate the switch.

G2.7.3. Specifications

- Disconnect switches must be rated for the voltage and current requirements of the particular installation
- Disconnect switches must be gang-operated
- Disconnect switches must be weatherproof or designed to withstand exposure to weather
- Disconnect switches must be lockable in both the open/closed positions with a standard PG&E lock.

G2.8. Fault-Interrupting Devices

The fault-interrupting device selected by the Generation Entity must be reviewed and approved by PG&E for each particular application.

There are two basic types of fault-interrupting devices:

- Circuit Breakers
- Circuit Switchers – Use by exception only. See G2.8.2.

PG&E will determine the type of fault-interrupting device required for a generation facility based on the size and type of generation, the available fault duty, the local circuit configuration, and the existing PG&E protection equipment.

G2.8.1. Circuit Breakers

A three-phase circuit breaker at the point of interconnection automatically separates the generation facility from the PG&E Power System upon detection of a circuit fault. Additional breakers and protective relays may be installed in the generation facility for ease in operating and protecting the facility, but they are not required for the purpose of interconnection. The interconnection breaker must have enough capacity to interrupt maximum available fault current at its location and be equipped with accessories to:

- Trip the breaker with an external trip signal supplied through a battery (shunt trip)
- Telemeter the breaker status when it is required
- Lockout⁴ if operated by protective relays required for interconnection

Generally, a three-phase circuit breaker is the required fault-interruption device at the point of interconnection, due to its simultaneous three-phase operation and ability to coordinate with PG&E line-side devices.

The required breakers must be trip tested (e.g. exercised) by the Generation Entity at least once a year.

G2.8.2. Circuit Switchers

New Circuit switchers are not approved because they do not have CT's and thereby increase exposure to the entire line section. Continued use of an existing an circuit switcher must meet the following requirements:

- Applicant must obtain PG&E's written approval.
- The IC rating is within the fault duty at the POI.
- Stand-Alone CT's must be installed on the PG&E (Utility Side) of the circuit switcher to minimize the amount of 3rd party equipment within the PG&E relay zone of protection.
- CT's must be relaying class CT's.

⁴ Lockout means a "lockout relay" prevents automatic or remote reclosing of the breaker. The lockout relay must be manually reset before closing the breaker.

- Stand-alone CT's will be insulation tested per TIH Section G5.1.1 "Proving Insulation".

G2.8.3. Relay Class Current Transformers (CT)

Metering class PT/CTs (including dual winding devices) must not be used for relaying purposes in PG&E's system. In particular, combination PT/CTs that are installed by PG&E for revenue metering purposes (including available taps) shall not be connected to customer relays and used to provide protection of customer-owned equipment.

A combination PT/CT is a device that is installed at the customer's point of connection to facilitate revenue metering of the power flow to or from PG&E's grid.

A dual winding metering PT/CT is a particular type of combination PT/CT that is constructed with a separate second CT core winding. Dual winding units are a non-standard device that is not stocked by PG&E.

Prior to 2001, there may be grandfathered cases where the customer installed a circuit switcher rather than a circuit breaker as an interrupting device, and dual winding PT/CTs were installed to provide protection for the customer's equipment. This practice was discontinued because the CTs in the metering unit do not meet relaying accuracy class standards. Also, if the dual winding unit should fail, PG&E should not be liable for protecting the customer's equipment.

G2.9. Synchronous Generators

The generating unit must meet all applicable American National Standards Institute (ANSI) and Institute of Electrical and Electronic Engineers (IEEE) standards. The prime mover and the generator should also be able to operate within the full range of voltage and frequency excursions that may exist on the PG&E Power System without damage to themselves. The generating unit must be able to operate through the specified frequency ranges for the time durations listed in [Table G2-9](#), to enhance system stability during a system disturbance.

G2.9.1. Synchronizing Relays

The application of synchronizing devices attempts to assure that a synchronous generator will parallel with the utility electric system without causing a disturbance to other customers and facilities (present and in the future) connected to the same system. It also attempts to assure that the generator itself will not be damaged due to an improper parallel action. Refer to Appendix Q for additional information and requirements.

Synchronous generators and other generators with stand-alone capability must use one of the following methods to synchronize with the PG&E Power System:

G2.9.1.1. Automatic Synchronizers Approved by PG&E See Table G2-7 for PG&E-approved devices.

Automatic synchronization with **automatic synchronizer** (Device 15/25) to synchronize with the PG&E Power System. The automatic synchronizer must be approved by PG&E and have all of the following characteristics:

- Slip frequency matching window of 0.1 Hz or less
- Voltage matching window of ± 10 percent or less
- Phase angle acceptance window of ± 10 degrees or less
- Breaker closure time compensation. For an automatic synchronizer that does not have this feature, a tighter phase angle window (± 5 degrees) with a one second time acceptance window shall be used to achieve synchronization within ± 10 degrees phase angle

Note: The automatic synchronizer has the ability to adjust generator voltage and frequency automatically to match system voltage and frequency, in addition to having the above characteristics.

G2.9.1.2. Automatic Synchronizers (not on PG&E’s approved list) Supervised by a PG&E-Approved Synchronizing Relay

Automatic synchronization with a device not approved by PG&E must be supervised by an approved **synchronizing relay** (Device 25). The synchronizing relay must have all of the following characteristics:

- Slip frequency matching window of 0.1 Hz or less
- Voltage matching window of ± 10 percent or less
- Phase angle acceptance window of ± 10 degrees or less
- Breaker closure time compensation

Note: The synchronizing relay closes a supervisory contact after the above conditions are met, allowing the non-approved automatic synchronizer to close the breaker.

G2.9.1.3. Manual Synchronization Supervised by a Synchronizing Relay

Manual synchronization with supervision from a **synchronizing relay** (Device 25) to synchronize with the PG&E Power System. The synchronizing relay must have all of the following characteristics:

- Slip frequency matching window of 0.1 Hz or less
- Voltage matching window of ± 10 percent or less
- Phase angle acceptance window of ± 10 degrees or less
- Breaker closure time compensation

Note: The synchronizing relay closes a supervisory contact, after the above conditions are met, allowing the breaker to close.

G2.9.1.4. Manual Synchronization with Synch-Check Relay

Manual synchronization with a synchroscope and synch-check (Device 25) relay supervision. (Only allowed for generators with less than 1000-kW aggregate nameplate rating). The synch-check relay must have the following characteristics:

- Voltage matching window of ± 10 percent or less.
- Phase angle acceptance window of ± 10 degrees or less.

Generators with greater than 1,000 kW aggregate nameplate rating must have a synchronizing relay or automatic synchronizer.

G2.9.2. Frequency/Speed Control

Unless otherwise specified by PG&E, a governor shall be required on the prime mover to enhance system stability. Governor characteristics shall be set to provide a 5 percent droop characteristic. Governors on the prime mover must be operated unrestrained to help regulate PG&E's system frequency.

G2.9.3. Excitation System Requirements

An excitation system is required to regulate generator output voltage.

Excitation systems shall have a minimum ceiling voltage of 150 percent of rated full load field voltage and be classified as a high initial response excitation system as defined in IEEE 421.1. Static Systems shall meet these criteria with 70 percent of generator terminal voltage. The offline generator terminal voltage response shall have an overshoot limited to 20 percent and a bandwidth of at least 0.1 to 4 hertz. However, in no case shall the bandwidth upper limit be less than local mode frequency. All systems shall be suitable to utilize a Power System Stabilizer as described in Section G2.9.4.

Ceiling current shall have a transient time capability equal to or greater than the short time overload capability of the generator. See ANSI C50.12, 13, or 14.

A means shall be provided to quickly remove excitation from the generator field to minimize contributions to faults. The preferred method is to reverse voltage the generator field to drive the current to zero.

Excitation systems shall respond to system disturbances equally in both the buck and boost directions. All bridges that govern excitation response shall be full wave type. Bridges feeding a pilot exciter shall have negative forcing capability.

PG&E written approval is needed for any exceptions or exemptions to this section.

G2.9.4. Voltage Regulator

Voltage control is required for all synchronous generators interconnected at transmission level voltages.

The regulator must be acting continuously and be able to maintain the generator voltage under steady-state conditions without hunting and within ± 0.5 percent of any voltage level between 95 percent and 105 percent of the rated generator voltage per CAISO requirements. The point of voltage sensing should be at the same point as the PG&E revenue metering.

Voltage regulators shall have a minimum of the following signal modifiers:

- Reactive current compensator capable of line drop or droop characteristic
- Minimum and maximum excitation limiter
- Volts per Hertz limiter
- Two levels of over-excitation protection. The first level should provide a forcing alarm and trip the voltage regulator after a time delay. The second level shall have an inverse time characteristic such that the time-current relationship may be coordinated with the generator short time thermal requirements (ANSI C50.13 or C50.14).
- A two input Power System Stabilizer (PSS) utilizing Integral of Accelerating Power to produce a stabilizing signal to modify regulator output. The PSS shall be an integral part of the voltage regulator and be incorporated into the excitation systems for all generating units greater than 30 MVA and connected to the transmission system at 60 kV and greater. PG&E can help determine, at the Generation Entity's expense, the suitability of an excitation system for PSS. The PSS shall provide a positive contribution to damping for a frequency range from 0.1 hertz through local mode frequency.

Voltage schedules will be determined by the PG&E Grid Control Center, in coordination with the CAISO.

At various times, the generating facility may also be requested by the Designated Electric Control Center, in coordination with the ISO, to produce more or less reactive power from that indicated on the regular schedule in order to meet the system needs.

G2.9.5. Power Factor Controller

The controller must be able to maintain a power factor setting within ± 1 percent of the setting at full load at any set point within the capability of the generator. However, in no case shall control limits be greater than (closer to 100%) between 90 percent lagging and 95 percent leading.

Power factor control is typically required for distribution level generator interconnections where the generator is put on a power factor schedule, rather than a voltage schedule. Power Factor Control shall not be used for units connected to the transmission system.

G2.10. Non-Synchronous Generators

Inverter based generation, including battery energy storage hybrid systems on the Bulk Energy System must be NERC compliant and in addition must comply with the following:

1. PRC-24-2 compliant for individual inverter voltage and frequency settings
2. FERC Order 827 compliant for power factor capability (See G3.5)
3. FERC Order 828, “Requirements for Frequency and Voltage Ride Through Capability of Small Generating Facilities”.

Table G2-5
Default Settings for Inverter Based Generation

	NEM and Non-Export Rule 21 Generating Facilities ≤ 1 MW		NEM and Non-Export Rule 21 Generating Facilities > 1 MW	
State	Setting	Rule 21 ² Reference	Settings	Reference
Anti-Islanding ¹	Activated	Section Hh.1.a.iii or P.1.a.iii	Deactivated	Anti-islanding not required per PRC 24
Low/High Voltage Ride-Through	Activated	Table Hh.1, or Table P-1b, Voltage Ride- Through Table	Activated	Per PRC 24
Low/High Frequency Ride Through	Activated	Table Hh.2, or P- 2b, Frequency Ride-Through Table	Activated	Per PRC 24
Dynamic Volt/VAR operations	Activated	Section Hh.2.j or P.2.j.	Activated	Per FERC Order 827
Ramp Rates	Activated	Section Hh.2.k or P.2.k.	Activated	Confirmed at time of commissioning, not to be applied in the Performance Tests
Fixed power factor	Deactivated	Section H.2.i	Deactivated	Per FERC Order 827
Reconnect by “soft start” methods	Activated	none	Activated	

Note 1 - For NEM (Net Energy Metering) installations in which the proposed generation will offset facility load, Anti-Islanding may be activated for installations up to 10MVA.

Note 2 – Inverters certified to UL 1741-SA will reference Rule 21 section Hh, those certified to UL 1741-SB will reference section P.

G2.11. Induction Generators

Induction generators and other generators with no inherent Var (reactive power) control capability shall be required to provide an amount of reactive power equivalent to that required for a synchronous generator. They may also be required to follow a PG&E-specified voltage or Var schedule on an hourly, daily or seasonal basis, depending on the location of the installation. Specific instructions shall be provided by the Designated PG&E Electric Control Center (see Section G3).

Induction machines can be self-excited with the nearby distribution capacitors, or as the result of the capacitive voltage on the distribution network. Interconnecting facility should provide for a reclose block mechanism to avoid unintended operation of the unit following an outage on the distribution feeder to which it is interconnected.

G2.12. DC Generators

G2.12.1. Inverter Based Generation Capable of Stand-Alone Operation

Inverter Based generators are generally not capable of stand-alone operation unless they are used for a microgrid or with standby generation. See G2.12.2. – Inverter Based Generation Incapable of Stand-Alone Operation.

Protection and Synchronizing requirements

For units capable of stand-alone operation, the generation and line protection requirements of Sections [G2.1](#) through [G2.5](#) shall apply. Additionally, the functional synchronizing requirements specified under [Section G2.9.1](#) shall apply to stand alone capable units.

Voltage Regulating Requirements for units connected to Transmission

Inverters do not have excitation systems similar to synchronous generators,, however they have the capability to regulate and follow voltage, therefore the unit shall meet the requirements to regulate output voltage and meet the requirements of [Section G2.9.3](#) and must meet the functional requirements of [Section G2.9.4](#) with the exception of the two levels of over-excitation protection. They shall also meet the requirements of [Section G2.9.6](#).

Regulation Requirements for units connected to Distribution

Inverters connected at the distribution level shall meet the requirements of [Section G2.9.5](#) for power factor control.

The total harmonic distortion in the output current of the inverters must meet ANSI/IEEE 519 requirements.

Inverter-type generators connected to the PG&E Power System must be pre-approved by PG&E. For units over 10 kW, a dedicated transformer will be required to minimize the harmonics entering into the PG&E Power System.

G2.12.2. Inverter Based Generation Incapable of Stand-Alone Operation

Inverter Based Generation incapable of stand-alone operation may not require all of the typical protection elements associated with synchronous generation. The requirements are noted below.

Protection Requirements

For units greater than 100kW the generation and line protection requirements of Sections [G2.1](#) through [G2.5](#) shall apply.

Synchronizing requirements

For units that are incapable of stand-alone operation synchronization is not required however there should be an undervoltage relay on the generation side of the PCC breaker to supervise breaker closing by preventing a close if voltage is on the generation bus.

Voltage Regulating Requirements for units connected to Transmission

Inverter Based Generations do not have excitation systems similar to synchronous generators,, however they have the capability to regulate and follow voltage, therefore the unit shall meet the requirements to regulate output voltage and meet the requirements of [Section G2.9.3](#) and must meet the functional requirements of [Section G2.9.4](#) with the exception of the two levels of over-excitation protection. They shall also meet the requirements of [Section G2.9.6](#).

G2.13. Remedial Action Scheme (RAS) Approvals

As stated in the WECC-NERC Planning Standards, the function of a Remedial Action Scheme (RAS) is to “detect abnormal system conditions and take pre-planned, corrective action (other than the isolation of faulted elements) to provide acceptable system performance.” In the context of new generation projects, the primary action of a RAS would be to detect a transmission outage or an overloaded transmission facility and then trip or run back (reduce) generation output to avoid potential overloaded facilities or other criteria violations.

Any RAS proposal must be approved by both PG&E and CAISO and must comply with “ISO Grid Planning Guides for New Generator Special Protection systems” section of the California ISO Grid Planning Standards.

G2.14. Remedial Action Scheme (RAS) Participation Requirement for Generation Facilities

As determined by PG&E, a generation facility may be required to participate in RAS to protect the grid.

A typical disturbance, as it is considered in the planning and design of the electric transmission system, is the sudden loss of one or more critical transmission lines or transformers. A widely applied corrective measure is to instantaneously drop a sufficient amount of generation on the sending end of the lost transmission facility. This

is known as *generation dropping*, and a participating generation facility may be disconnected from the transmission by the automatic RAS controller, in much the same way as by a transfer-trip scheme. A generation facility should therefore have full load-rejection capability as needed both for local line protection and RAS. The RAS design must be such that any single-point failure will not prevent the effective operation of the scheme.⁵

Whether RAS shall be required will depend on the overall location and size of the generator and load on the transmission system, the nature, consequences and expected frequency of disturbances and the nature of potential alternative transmission reinforcements

G2.15. Event Recording

All unattended generation facilities with capacity greater than 400 kW and with automatic or remotely initiated paralleling capability must have event recording capability that will enable PG&E to make an after-the-fact determination of the status of the Generation Facility at the time of the system disturbance, should such a determination be required. The events should be recorded to a one (1) milli-second resolution or a minimum of 16 samples per cycle and should include oscillography and sequence of events recording (SER). This requirement may be satisfied via the event recording capability of the facilities installed microprocessor relays.

The above does not remove the requirement for Event Recording requirements as specified in NERC PRC -002-2 "Disturbance Monitoring and Reporting Requirements". Each installation is responsible for conformance to NERC standards.

G2.16. Emergency Generator Requirements

There are two methods of transferring electric power supply between the PG&E source and the emergency generator system: open transition (break before make) and closed transition (make before break).

G2.16.1. "Break Before Make"

This method can be accomplished via a double throw transfer switch or an interlock scheme that prevents the two systems from operating in parallel. The Generation Entity's main breaker shall not be allowed to close until the generator breaker opens. This open transition method does not require any additional protection equipment; however, it does cause the Generation Entity's load to experience an outage while transferring back to PG&E. The length of this transfer depends on the transfer equipment.

⁵ System studies will determine the nature and intent of the RAS. Any RAS proposals to mitigate possible cascading outages outside the PG&E interconnection points or system requires review and approval by the appropriate WECC study groups and technical committees charged with detailed review.

G2.16.2. “Make Before Break”

This method is used when the customer wants to minimize any loss of power or disturbance to the electric load. With this scheme, the customer's generator and the PG&E Power System are in parallel for a very short time interval⁶ during which the customer's load is being transferred between the PG&E source and the emergency generator. Both the transfer from PG&E to the emergency source and the transfer back can be accomplished without an outage.

G2.16.3. Interconnection Requirements

Listed below are the requirements for the interconnection of emergency generators using the transfer schemes. First the general requirements for all transfer schemes are presented. Then the specific requirements for the two methods are listed.

G.2.16.3.1. Interconnection Protection Study⁷

In general, a protection study is not required for these types of generation arrangements if the applicant meets the requirements outlined in this section and submits the required reports and drawings for review and approval.

G.2.16.3.2. Transfer Switch

The transfer switch must be rated for the maximum possible load current.

G.2.16.3.3. Notification and Documentation

1. The customer must notify PG&E in writing regarding all emergency generator installations, regardless of method of interconnection or transfer.
2. Complete documentation is required. Information should include but not limited to: a description of generator and control system operation, single line diagrams, identification of all interlocks, sequence of events description for transfer operation and specifications for any PG&E required protective devices.
3. All documentation must be approved by PG&E prior to installation.
4. Relay test reports must be reviewed and approved by PG&E 30 days prior to scheduling pre-parallel inspections.

G2.16.3.4. Operation/Clearance

1. For all line work and clearances, the emergency generator should be treated as a power source.

⁶ See G2.15.3.6.1 – a very short time interval is typically under 30 cycles for transmission facilities

⁷ Note: This is a different study, not to be confused with a System Impact Study, see glossary for definitions

2. Customers utilizing “make before break” transfer schemes are required to notify the responsible Operation Center of their intent to transfer to their emergency generator and then again back to PG&E source, before any transfers are attempted. This notification is not required for break before make operation.

G2.16.3.5. “Break Before Make” Specific Requirements

G2.16.3.5.1. Transfer Switch

The transfer switch must be of a design, or have an interlock, that prevents the transfer switch from closing and connecting the customer’s system with PG&E unless the emergency generator is already removed from the system.

G2.16.3.6. “Make Before Break” Requirements

G2.16.3.6.1. Transfer Switch

1. The transfer switch must be rated for the maximum available fault duty in the event that the transfer switch closes into a fault condition.
2. There must be an interlock that will trip the main breaker or generator in the event of a failure of the transfer switch so that the unit will not remain paralleled to the PG&E Power System. This can be accomplished via a failure to open timer (see [Table G2-7](#)) for approved timers.
3. The controls for the transfer switch must prevent a parallel condition of the customer generator and the PG&E Power System from existing for an extended time period. Any system that allows a parallel to exist for greater than 0.5 seconds (30 cycles) on the transmission system and 1 second (60 cycles) on the distribution system should be subjected additional requirements outlined in other section of this document.

G2.16.3.6.2. Manual Disconnect

1. The customer must provide a manual disconnect, located at the point of interconnection, which is used to establish a visually open safety clearance for the PG&E personnel working on the PG&E Power System.
2. The disconnect must be lockable in either the open or closed transition and operated only by PG&E.
3. The disconnect must be easily accessible, preferably located adjacent to the electric meter.
4. The disconnect must have full load break capability.

G2.16.3.6.3. Synchronizing Function

The transfer scheme must have adequate control and protection to ensure the PG&E and customer electric systems are in synchronism prior to making the parallel. This is essential to ensure a safe and smooth transition. Synchronization is accomplished through the use of an auto-synchronizer or a synchronizing relay. The major requirements that these devices should possess are briefly listed below:

1. Slip frequency matching of 0.1 Hz or less.
2. Voltage matching of ± 10 percent or less.
3. Phase angle acceptance of ± 10 degrees or less.
4. Breaker closure time compensation.

G2.16.3.6.4. Protection

Because the emergency generators are paralleled with the PG&E Power System, protective devices must be installed which will prevent the customer's generator from remaining connected in the event of a fault occurring on the PG&E Power System during the transition. It is necessary to prevent damage to the customer's equipment, the PG&E Power System, and other PG&E customers.

1. In most installations, the protection requirement may be satisfied through the installation of the reverse power relay (see [Table G2-7](#)). This relay should be installed on the customer's side of the service transformer that is connected to the PG&E Power System. The relay should trip the customer's main breaker and must be able to detect transformer core magnetizing power. In this manner, reverse power flow is detected before it actually enters the PG&E Power System and other customers' equipment. This can be accomplished by setting the current level pick up equivalent to 60 percent of the transformer bank magnetizing current. Because this current value will be small, the current transformers associated with the relay must be capable of providing these small currents.
2. When transferring the customer's load back to the PG&E Power System. It is possible to have incidental power flow back to PG&E's system. By properly setting the synchronizing and/or generator control, this reverse flow can be avoided. However, a short time delay may be required on the reverse power relay to prevent it from tripping the generator unnecessarily each time a transfer is attempted. At no time should this time delay exceed one second.

G2.16.3.6.5. Dedicated Transformer

Due to the fact that the emergency generator is connected in parallel with the PG&E Power System, all transfer schemes of this type must have a dedicated transformer. This will lessen the possibility that any transfer activities will affect other PG&E customers. In addition, a dedicated transformer is also necessary to allow the installation of the reverse power relay scheme.

G2.17. Parallel-only (NO sale) Generator requirement

Parallel-Only generators shall have similar requirements as that of any other standard synchronous generator interconnection except that PG&E may at its discretion allow the installation of three very sensitive, single-phase, reverse power relays (such as the Basler BE1-32R) along with the dedicated transformer as an alternative to the normally required ground relays. The reverse power relays shall be set to pick up on transformer magnetizing current with a time delay not to exceed 0.5 second. This option may not be feasible on generating systems with a slow load rejection response since they may be tripped off-line frequently for in-plant disturbances.

Owners of Parallel-Only generators, particularly Rule 21 customers must execute a parallel-only operating agreement with PG&E prior to operation by the generation owner.

G2.18. GENERATION ENTITY-Owned Primary or Transmission Voltage Tap Lines (above 60 kV and below 100 kV)

If the Generation Entity constructs, owns and maintains a transmission-level voltage tap line extension, the entity shall also install, own and maintain the following equipment at the point of interconnection with PG&E:

- The fault-interrupting protection device; i.e., breaker, recloser, as specified by PG&E.
- The manual isolating disconnects (gang-operated).
- High-side metering installation as outlined in Section G1.

G2.19. PG&E Protection and Control System Changes which may be Required to Accommodate Generator Interconnection

At the Generation Entity's expense, PG&E will perform a detailed interconnection study to identify the cost of any required modifications to PG&E's protection and control systems that are required to interconnect a new generation source. Retail generators will execute a Generation Special Facilities Agreement (Appendix L) as indicated in [Electric Rule 21](#) to recover the costs to PG&E associated with any protection and control system modifications which are directly assigned to the Generation Entity. Wholesale generators will execute a FERC-jurisdictional Generator Interconnection Agreement.

These protection and control system modifications are in addition to any transmission system upgrades identified in the system impact or facilities studies for interconnection of the new generation facility.

Following is a partial list of protection system modifications that may be required:

- PG&E's automatic restoration equipment shall be prevented from operating until the generator is below 25 percent of nominal voltage as measured at the restoration equipment. Generator damage and system disturbances may result from the restoration of power by automatically re-energizing PG&E's facilities. This modification shall be required when the generator(s) has the capability of energizing a line when the PG&E Power System is disconnected. PG&E will not allow the Generation Entity's generator(s) to automatically re-energize PG&E facilities.
 - The exception to the above is for a switching station which intersects a PG&E transmission line in which auto-reclosing is used to maintain reliability. In those cases, PG&E will determine the auto-reclosing requirements. For 500kV systems, the existing single pole tripping (selectable to either single pole or three pole) and high speed reclosing are to be maintained. Single pole operation requires pole disagreement and lead/follow protection reclosing practice as detailed in the protection requirements for each interconnection.
- Installation of transfer trip from the high-side circuit breaker/circuit switcher, as well as the distribution breaker and any line reclosers, to the generator if found necessary by PG&E. An associated EMS/SCADA telemetering circuit is continuously required between the Generation Entity's site and the Designated PG&E Electric Control Center.

G2.20. Direct Telephone Service

The Generation Entity must obtain direct service from the local telephone company for a business telephone so that operating instructions from PG&E can be given to the designated operator of the Generation Entity's equipment. In addition, another telephone must be available near the protection equipment and telemetering equipment. This telephone would be used for maintenance clearances of the various communication and protection system equipment that may be in service. Other types of leased circuits would include protection and EMS/SCADA data circuits.

Communications circuits for transfer trip and EMS/SCADA must be in service at least three weeks prior to connection to the PG&E power grid. Once EMS/SCADA is in service then "continuous" telemetry is required. It is critical to the project schedule that the required leased circuits are ordered many months in advance of the operational date. In Appendix F, approximate timeframes are provided for different types of circuits and services. These are approximate lead times for planning purposes. The telephone company will need to determine whether adequate cable pair facilities are available at each facility for the required service. If cable plant is not available, the generator should plan on 6-12 months before having the service.

A Telephone line may also be required for remote metering at the Gas Valve location as appropriate. PG&E telecommunications personnel should evaluate this installation to make sure that the proper precautions are taken to ensure that the dielectric strength of the cable and protection equipment at the termination points of the cable are adequate to meet safety criteria.

G2.21. Standby Station Service

Contact PG&E's local representative if the Generation Entity desires standby service for station use.

G2.22. Station Battery

A stationary battery, a flooded lead acid type is required to power utility grade relays and for tripping the breaker. For detailed requirements about type, calculations and design, and test reports, etc., please refer to [Appendix T](#)- "Battery Requirements for Interconnection to PG&E System".

Table G2-6
STANDARD DEVICE NUMBERS

Device Number	Definition and Function
15	Speed of frequency matching device is a device that functions to match and hold the speed or the frequency of a machine or of a system equal to, or approximately equal to, that of another machine, source or system.
21	Distance Relay is a device which functions when the circuit admittance, impedance, or reactance increases or decreases beyond predetermined limits.
25	Synchronizing, and synchronism-check , device operates when two a-c circuits are within the desired limits of frequency, phase angle and voltage, to permit or to cause the paralleling of these two circuits.
27	Undervoltage relay is a device that functions on a given value of undervoltage.
32	Reverse power relay is one which functions upon a reverse power flow at a given set point.
46	Reverse-phase or phase-balance, current relay is a device which functions when the polyphase currents are of reverse-phase sequence, or when the polyphase currents are unbalanced or contain negative phase sequence components above a given amount.
47	Phase-sequence voltage relay is a device that functions upon a predetermined value of polyphase voltage in the desired phase sequence.
50	Instantaneous overcurrent, or rate-of rise relay is a device which functions instantaneously on an excessive value of current, or on an excessive rate of current rise, thus indicating a fault in the apparatus or circuit being protected.
51	A-C time overcurrent relay is a device with either a definite or inverse time characteristic that functions when the current in an a-c circuit exceeds a predetermined value.
52	A-C circuit breaker is a device that is used to close and interrupt and a-c power circuit under normal conditions or to interrupt this circuit under fault or emergency conditions.

Table G2-6
STANDARD DEVICE NUMBERS (Continued)

Device Number	Definition and Function
59	Overvoltage relay is a device that functions on a given value of overvoltage.
60	Voltage balance relay is a device which operates on a given difference in voltage between two circuits.
61	Current balance relay is a device that operates on a given difference in current input or output of two circuits.
62	Time-delay stopping, or opening, relay is a time-delay device which serves in conjunction with the device which initiates the shutdown, stopping , or opening operation in an automatic sequence.
67	A-C directional overcurrent relay is a device that functions on a desired value of a-c overcurrent flowing in a predetermined direction.
79	A-C reclosing relay is a device that controls the automatic reclosing and locking out of circuit interrupter.
81	Frequency relay is a device that functions on a predetermined value of frequency—either under or over the normal system frequency—or rate of change of frequency.
87	Differential protective relay is a protective device which functions on a percentage or phase angle or other quantitative difference of two currents or of some other electrical quantities.
90	Regulating device functions to regulate a quantity, or quantities, such as voltage, current, power, speed, temperature, frequency, and load, at a certain value or between certain limits for machines, tie lines, or other apparatus.
94	Tripping or trip-free relay is a relay that functions to trip a circuit breaker, contactor, or equipment, or to permit immediate tripping by other devices; or to prevent immediate reclosure of a circuit interrupter if it should open automatically even though its closing circuit is maintained closed.

Form G2-2

RELAY TEST REPORT

FACILITY NAME		TESTING BY		DATE INSTALLED			
LOCATION		FIRM		DATE LAST TESTED			
		ADDRESS					
FACILITY ACCOUNT NUMBER		TESTED FOR					
		INSTALLATION		ROUTINE OTHER			
RELAY INFORMATION					SETTINGS		
DEVICE NO		FUNCTION					
MFR.		TYPE		STYLE			
TIME RANGE		INST. RANGE					
OHMIC RANGE @ ANGLE		OFFSET					
CT RATIO		PRI. MIN.		PRI. INST.			
DEVICE NO		FUNCTION					
MFR.		TYPE		STYLE			
TIME RANGE		INST. RANGE					
CT RATIO		PRI. MIN.		PRI. INST.			
DEVICE NO		FUNCTION					
MFR.		TYPE		STYLE			
TIME RANGE		INST. RANGE					
CT RATIO		PRI. MIN.		PRI. INST.			
DEVICE NO		FUNCTION					
MFR.		TYPE		STYLE			
TIME RANGE		INST. RANGE					
CT RATIO		PRI. MIN.		PRI. INST.			
DIRECTIONAL ELEMENTS:		DEVICE NO.		DEVICE NO.			
CONTACTS:		A PHASE	B PHASE	C PHASE	GROUND		
CLOSED TO OPEN AT: (DEG. I LAG E)							
OPEN TO CLOSED AT: (DEG. I LAG E)							
MAXIMUM TORQUE AT: (DEG. I LAG E)							
MIN. P.U.: EXI:							
IXI:							
TIME ELEMENTS:		DEVICE NO.		DEVICE NO.			
TIMES TAP	CURVE	TEST			TIMES TAP	CURVE	TEST
		A PHASE	B PHASE	C PHASE			
INST. P.U. CURRENT				INST. P.U. CURRENT			
PRIMARY "ONE-SECOND" GROUND CURRENT (JOINT POLE)							
TIME ELEMENTS:		DEVICE NO.		DEVICE NO.			
TIMES TAP	CURVE	TEST			TIMES TAP	CURVE	TEST
		A PHASE	B PHASE	C PHASE			
INST. P.U. CURRENT				INST. P.U. CURRENT			
PRIMARY "ONE-SECOND" GROUND CURRENT (JOINT POLE)							

Table G2-7

RELAYS FOR GENERATION APPLICATION^{2,4}

(For Directional Overcurrent and Distance Relays, refer to
[Table G2-8](#)) (See notes on following page)

DEVICE	Synch Check Relay	Synchronizing Relay ⁷	Automatic Synchronizer ⁷	Undervoltage Relay ¹⁵	Non-directional Overcurrent Relay	Non-directional Overcurrent Relay Ground	Overcurrent with Voltage Restraint or Voltage Control	Overvoltage Relay ¹⁵	Overvoltage ⁵ Ground Fault Detection (Neutral)	Frequency Relay (Under/Over)	Under, Over, & Reverse Power ¹¹	Time Delay
Device Number	25	25	15/25	27	50/51 ⁸	51N	51V ^{3,6,8}	59	59N	81U/O	32	62
MANUFACTURER												
ABB REx670 includes REB,REC,RED, REG,REL,RER, RES,RET		REF 615 REF 620	REF 615 REF 620	DPU-2000R REF 615 REF 620	DPU-2000R REF 615 REF 620 REx-670	DPU-2000R REF 615 REF 620		DPU-2000R REF 615 REF 620	REF 615 REF 620	DPU-2000R REF 615 ¹⁸ REF 620 ¹⁸ REx-670		REF 615 REF 620 REx-670
AREVA	MAVS			MiCOM, P344	MCGG MiCOM P643, P344	MCGG		MiCOM P921, P923,P344	MiCOM P921, P923	MiCOM P344		MVTT
Basler Electric	BE1-25 BE1-GPS BE1-IPS BE1-11i BE1-11g	BE1-11i BE1-11g	BE1-25A BE1-11i BE1-11g	BE1-27 BE1-GPS BE1-IPS BE1-11i BE1-11g	BE1-51 BE1-GPS BE1-IPS BE1-11i BE1-11g	BE1-51 BE1-GPS BE1-IPS BE1-11i BE1-11g	BE1-51/27R ⁸ BE1-51/27c ⁸ BE1-GPS BE1-IPS BE1-11i ³ BE1-11g ³	BE1-59 BE1-GPS BE1-IPS BE1-11i BE1-11g	BE1-59N BE1-GPS BE1-IPS BE1-11i BE1-11g	BE1-81 O/U BE1-GPS BE1-IPS BE1-11i BE1-11g	BE1-32R BE1-GPS ¹² BE1-IPS ¹³ BE1-11i ¹³ BE1-11g ¹³	BE1-GPS BE1-IPS BE1-11i BE1-11g

PG&E Transmission Interconnection Handbook

Beckwith Electric	M0390 M3410 M-3410A M3520	M-0193	M-0193 M-0194	M-0296 M-0420 M-3410 M-3410A M-3411A M-3420 M-3425 M-3425A M-3430 M-3520	M-0420 M-3410 M-3411A M-3420 M-3435 M3425A M-3430 M-3520	M-0420 M-3425 M-3425A M-3410 M-3520	M-3420 M-3425 M-3425A M-3410 M-3410A M-3520	M-0296 M-0420 M-3410 M-3410A M-3411A M-3420 M-3425 M-3425A M-3430 M-3520	M-3425 M-3425A M-3430 M-3520	M-0296 M-0420 M-3410 M-3410A M-3420 M-3425 M-3425A M-3430 M-3520	M3410 ¹² M3410A ¹² M3520	
Cooper				IDP-210	IDP-210	IDP-210		IDP-210		IDP-210	IDP-210	
Cutler Hammer			IQ Transfer									IQ

DEVICE	Synch Check Relay	Synchronizing Relay ⁷	Automatic Synchronizer ⁷	Undervoltage Relay ¹⁵	Non-directional Overcurrent Relay	Non-directional Overcurrent Relay Ground	Overcurrent with Voltage Restraint or Voltage Control	Overvoltage Relay ¹⁵	Overvoltage Ground Fault Detection (Neutral)	Frequency Relay (Under/Over)	Under, Over, & Reverse Power ¹¹	Time Delay
Eaton					EDR 3000 EDR 5000	EDR3000 EDR5000						
General Electric (Multilin)	D-60 F-60 L-90		Mark V Mark VI	SR-489 D-60 L-90 T-60 F-60 F-35	SR-489 SR-745 D-60 F-60 F-35 L-90 T-60 SR-735 SR-737	SR-489 SR-745 D-60 F-60 F-35 L-90 T-60 SR-735 SR-737	SR-489 F-60 F-35	SR-489 SR-745 D-60 L-90 T-60 F-60	SR-489 F-60	SFF SR-489 (two steps) F-60 D-60 T-60	SR-489 F-60	D-60 L-90 F-60 F-35

PG&E Transmission Interconnection Handbook

Schweitzer	SEL-300G SEL-311C SEL-311L SEL-351-5,6,7/351S SEL-451 SEL-700G SEL 700GT SEL-751/751A SEL-400G SEL-787	SEL-351-5,6,7 SEL-351S SEL-700G SEL-700GT SEL-300G SEL-751/751A SEL-400G SEL-787	SEL-700G SEL-700GT	SEL-300G SEL-700G SEL 700GT SEL-311C SEL-311L SEL 751/751A SEL-321 SEL-351-5,6,7/351A/ 351S SEL-387E SEL-411L SEL-421 SEL-451 SEL487E SEL-400G SEL-787	SEL-300G SEL-700G/GT/GW SEL-311C SEL 751/751A SEL-321 SEL-351-5,6,7/351A/ 351S SEL-387 SEL-387A SEL-387E SEL-501 SEL-551 SEL-587 SEL-411L SEL-421 SEL 311L SEL-451 SEL487E SEL-400G SEL-787	SEL-300G SEL-700G/GT/GW SEL-501 SEL-321 SEL-351-5,6,7/351A/ 351S SEL-387 SEL-387A SEL-387E SEL-551 SEL-411L SEL-421 SEL 311L SEL-451 SEL487E SEL-400G SEL-787	SEL-300G SEL-700G SEL-700GT SEL-351-6,7 ¹⁹ SEL-400G	SEL-300G SEL-700G SEL-700GT SEL-311C SEL-311L SEL-321 SEL-351-5,6,7/351A/ 351S SEL-387E SEL-411L SEL-421 SEL-451 SEL487E SEL-400G SEL-787	SEL-300G SEL-700G SEL-700GT SEL-311C SEL-311L SEL-351-5,6,7 SEL-351S SEL-400G SEL-787	SEL-300G SEL-700G SEL-700GT SEL-311C SEL-311L SEL-351-5,6,7/351A/ 351S SEL-387E SEL-411L SEL-421 SEL-487E SEL-400G SEL-787	SEL-351-7 ¹⁷ SEL 751 ²⁰ SEL700G ²⁰	SEL-300G SEL-700G SEL-700GT SEL-311C SEL-387 SEL-501 SEL-351-5,6,7 SEL-387E SEL-411L SEL-421 SEL-387E SEL-551 SEL-411L SEL-421 SEL-451 SEL487E SEL400G SEL-787
Siemens	7SJ64	7VE61 7VE63	7VE61 7VE63	7SJ64 7SJ80 7UM62 7UT613 7VE63	7SJ82/7SJ85	7SJ82/7SJ85	7UM62	7SJ64 7SJ80 7UM62 7UT613 7VE63		7SJ64 7SJ80 7UM62 7UT613 7VE63		
Woodward			SPM 9905-005 DSLCL MSLC DSM 9905-204									

Notes for Table G2-7:

1. Intentionally Left Blank
2. All microprocessor-based relays that are applied as a multifunctional protection device will require backup relays. (Alternate or backup protective relays can be electromechanical, solid state, or microprocessor-based relays.) Most microprocessor relays include event reporting and fault locating functions. Relay settings, sequences of events listing, and fault records should not be lost or revert to default values when DC source is momentarily lost. Event and Oscillography should not be erased from the relay records when the front panel reset button is exercised to reset the Target LCD display.
3. Voltage restrained overcurrent relays are preferred; however, if no problems with protective coordination occur, voltage controlled relays may be used. An auxiliary potential transformer is required for the 51V if the main interconnecting transformer is a wye-delta bank and the relay does not automatically adjust for appropriate phase shift.

PG&E Transmission Interconnection Handbook

4. The above table contains information regarding specific products, manufacturers and representatives. These tables are not all inclusive. The inclusion or omission of products, a manufacturer or representative is not meant to be an indication of the quality or reliability of a product or service. No endorsements or warranties are implied. Other types of relays may be acceptable but certified test results performed by an independent party must be reviewed and approved by PG&E prior to installation and commercial operation. This table contains new generation relays for older or “legacy” relays contact PG&E to determine if the relay was previously approved.
5. Intentionally Left Blank
6. Distance characteristic relays can be used as an alternate to using voltage restraint relays when system conditions coupled by unit characteristics permit.
7. Synchronizing devices must be ordered with the following option: a) voltage matching, b) phase angle acceptance, c) slip frequency acceptance, and d) breaker time compensation.
8. Three single phase units are implied, a single three-phase overcurrent relay is acceptable if a redundant system is provided. There may be occasions when a three-phase 51V/27R relay may not be applicable.
9. Manual synchronization with synch-check relay and synchroscope only allowed for generators with less than 1000kW aggregate nameplate rating.
10. The Beckwith M-0193 and M-0194 work in conjunction to provide the Automatic Synchronizer function.
11. For reverse power applications, the relay sensitivity should be evaluated to meet the transformer magnetizing current requirements for reverse power, see Appendix R.
12. Basler BE1-GPS and Beckwith M3410 have 3 phase measuring power elements. Basler BE1-IPS and Beckwith M3410A and M3520 have three single-phase measuring elements for power measurements and protection computations. The Basler BE1-32R is a single-phase unit, one per phase is required for protection applications. Refer to note 11 prior to selection of the devices as different relays have different measuring sensitivity elements. For example, Beckwith M3410A sensitivity is approximately 0.75 mA of real power component, whereas Beckwith M-3520 has a sensitivity of 10mA of real component current. The IPS 32 function is suitable for low forward type detection and is suitable for conditions where the power factor is greater than 0.1.
13. The over / under power function of the Basler IPS, 11g and 11i have user settable 32 setting elements that can utilize combination of 1 of 3, 2 of 3, 3 of 3, or total 3-phase power. Verify the user has three phase-to-neutral voltage sources and the relay is set to the 1 of 3 phase power option to meet PG&E’s single phase over / under power requirements. The 11g and 11i must have 60FL block disabled on the 32 settings.
14. Auxiliary voltage measuring element is required to make use of the Basler BE1-GPS synchronizing check setting option.
15. Multi-function devices in this column have the features that may be utilized provided that the voltage source is utilized. The voltage sensing logic in different styles from the same manufacturer or between different manufacturers may not have capability for loss of voltage detection to alarm, when single phase voltage is used.
16. All relays must have 5A nominal AC input current.
17. For SEL-351-7 this relay is not approved for protective purposes since a secondary voltage < 40AC will prevent operation of the relay. For uses other than protection verify that the application meets the minimum sensitivity of the relay before selection. The minimum sensitivity of the relay is 3.48 watts secondary ($0.05A * 69v + 0,033VA = 3.48 VA$ single phase). This relay is approved for Rule 21 "Minimum Import" applications for settings no less than 3.5 watts secondary. In general, the relay is not approved for reverse power applications (0.1% of bank rating) unless calculations demonstrate that it can be set above the minimum sensitivity.
18. ABB REF 615 and 620 may delay 81 tripping by 10 cycles due to internal “loss of mains” logic.
19. SEL 351-6,7 does not have a 51V element or a dedicated 51C (voltage controlled element), however the 51C functionality can be obtained by logically “anding” or torque controlling the phase overcurrent and undervoltage elements.

June 12, 2023

Internal

PG&E Transmission Interconnection Handbook

20. SEL-751, 700G, is approved for protective and reverse power applications when set per SEL Application Guide AG2021-26 “Single-Phase Reverse Power Elements in 700G and SEL 751 Relays.” Reference the application guide when determining minimum relay sensitivity. This relay may also be applied for underpower applications, contact Schweitzer Engineering Laboratories (SEL) or PG&E for “Under-Power” applications.

Table G2-8

Relays for Generation Interconnection Application

(For Voltage, Overcurrent, and Frequency Relays, See [Table G2-7](#))

(See notes on following page)

DEVICE	Distance Relay Zone 1	Distance Relay Zone 2	Distance Zone 2 Pilot Protection	Distance Relay Zone 3 Blocking Pilot	Distance Relay Gnd Distance	Directional Time Overcurrent Phase	Directional Time Overcurrent Ground	Directional Overcurrent Pilot (Phase and Ground)	Current Differential or Phase Comparison	Auxiliary
DEVICE NUMBER	21	21 Z2	21 Z2C	21Z3C	21Z2G	67	67N	67NC	87L / 78	94
MANUFACTURER										
ABB (ASEA) (Westinghouse)	REL-512	REL-512	REL-512	REL-512	REL-512	REL-512 REF 615 REF 620	REL-512	REL-512	REL-350	AR MG-6 SG
AREVA	OPTIMHO QUADRAMH	OPTIMHO QUADRAMH	OPTIMHO QUADRAMHO	OPTIMHO QUADRAMH	OPTIMHO QUADRAMH		OPTIMHO QUADRAMH	OPTIMHO QUADRAMH	LFCB	MVAJ
Basler Electric	BE1-11g	BE1-11g				BE1-67 BE1-IPS BE1-11g BE1-11i	BE1-IPS BE1-11g ¹ BE1-11i ¹			
Beckwith	M3425 M3430 M3520	M3425 M3430 M3520				M3520	M3520			
General Electric	SR-489 D-60	SR-489 D-60	D-60	D-60	D-60 L-90	D-60 F-60 T-60	D-60 F-60	D-60 L-90	L-90	HFA HGA
Schweitzer	SEL 300G SEL 700G SEL-311C SEL 321 SEI-421 SEL-311L SEL-411L	SEL 300G SEL 700G SEL-311C SEL 321 SEL-421 SEL-311L SEL-411L	SEL-311C SEL 321 SEL-421 SEL-311L SEL-411L	SEL-311C SEL 321 SEL-421 SEL-311L SEL-411L	SEL-311C SEL 321 SEL-421 SEL-311L SEL-411L	SEL-311C SEL 351 SEL-421 SEL-311L SEL-411L	SEL-311C SEL-321 SEL 351 SEL-421 SEL-311L SEL-411L	SEL-311C SEL-311L SEL-321 SEL-351 SEL-421 SEL-311L SEL-411L	SEL-311L SEL-411L	

Notes for Table G2-8

- The above table contains information regarding specific products, manufacturers and representatives. This table is not all-inclusive. The inclusion or omission of a product, manufacturer or representative is not meant to be an indication of the quality or reliability of a product or service. No endorsements or warranties are implied. Only PG&E approved relays may be installed for protection of interconnecting distribution or transmission lines. Refer to Appendix F for direct transfer trip (DTT) and pilot protection requirements when applicable. This table contains new generation relays for older or “legacy” relays contact PG&E to determine if the relay was previously approved.
- Most microprocessor relays include event reporting and fault locating functions. Relay settings, event, and fault records should not be lost or revert to default values when DC source is momentarily lost. Event and Oscillography should not be erased from the relay records when the front panel reset button is exercised to reset the Target LCD display.
- All microprocessor based relays being used as a multifunctional protection device will require backup relays, except for generation less than 400 kW aggregate nameplate with relay failure output contact connected to trip the generation breaker. (Alternate or backup protective relays can be electromechanical, solid state, or microprocessor based relays.)
- Primary and alternate protective devices must utilize different operating principals and not be subject to possible common mode failures in order to minimize the potential for insufficient interconnection protection, where applicable or unnecessary plant shut down; for example, due to possible product advisory letters issued by the manufacturers.
- All relays must have 5A nominal AC input current.

1-Basler BE1-11i and BE1-11g cannot be polarized by an external vx voltage input due to a high sensing threshold. The other three polarizing methods are acceptable.

Table G2-9
OVERFREQUENCY AND UNDERFREQUENCY RELAYS
OVERVOLTAGE AND UNDERVOLTAGE RELAYS
Transmission System Interconnection

Over^{1,2,3,4 7,8,9} Frequency	Under ^{1,2,4 7,8,9} Frequency	Over^{5 7 8,9} Voltage (pu)	Under^{6 7 8,9} Voltage (pu)
>60.6 Hz @ 180 sec	<59.4 Hz @ 180 sec	≥1.20 @ instantaneous	<0.45 @ (0.15 (sec)
>61.6 Hz @ 30 sec	<58.4 Hz @ 30 sec	≥1.175 @ 0.20 (sec)	<0.65 @ 0.30 (sec)
N/A	<57.8 Hz @ 7.5 sec	≥1.15 @ 0.50 (sec)	<0.75 @ 2.00 (sec)
N/A	<57.3 Hz @ 45 cycles	≥1.10 @1.00 (sec)	<0.90 @ 3.00 (sec)
≥61.7 Hz @ 0 sec	57.0 Hz @ 0 cycles	N/A	N/A

Notes:

1. All settings meet WECC Off-Nominal Frequency requirements. The frequency settings must not allow less stringent operation of the generation facility than specified in the WECC Off Nominal Frequency Requirements.
2. Generators may use electro-mechanical frequency relays only for settings outside the 57.9 -61.0 Hz range.
3. All Frequency relays must use the definite time characteristic specified in Table G2.8. They should not be disabled for voltages 70% of nominal or higher.
4. WECC allows generators to have UF/OF settings within the no trip zone if the generator somehow arranges for an equivalent amount of load to be tripped at the same time that the generator trips refer to Section E.13 of the WECC Plan.
5. The over/undervoltage relay settings are intended to indicate POI voltages and times for which the generator is expected to remain online in accordance with PRC-024. Actual relay settings are to be made by the generator owner based on their protection requirements while satisfying the listed limits.
6. For undervoltage relays, set time delay typically at 3 to 5 seconds at zero voltage to allow for motor starting and for coordination of line protection devices

7. Voltage requirements are based on NERC PRC 24-2 and will apply to BES and non-BES for consistency
8. The voltage and frequency requirements also apply to on-board inverter AC output protection elements.
9. Momentary Cessation is not allowed in the No Trip Zones.

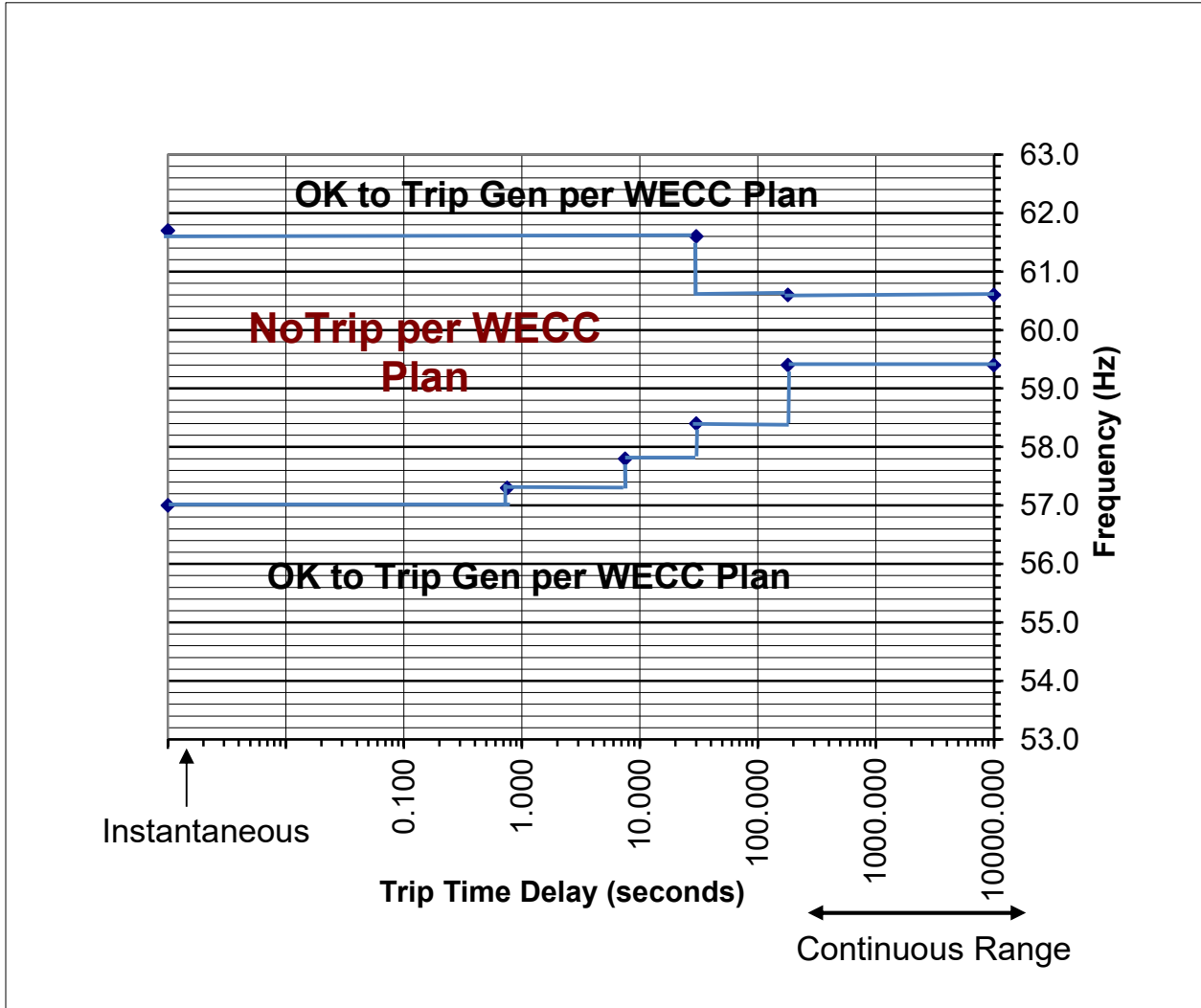

Figure 1
Generator Under / Over Frequency
Trip Points & Zone Boundaries

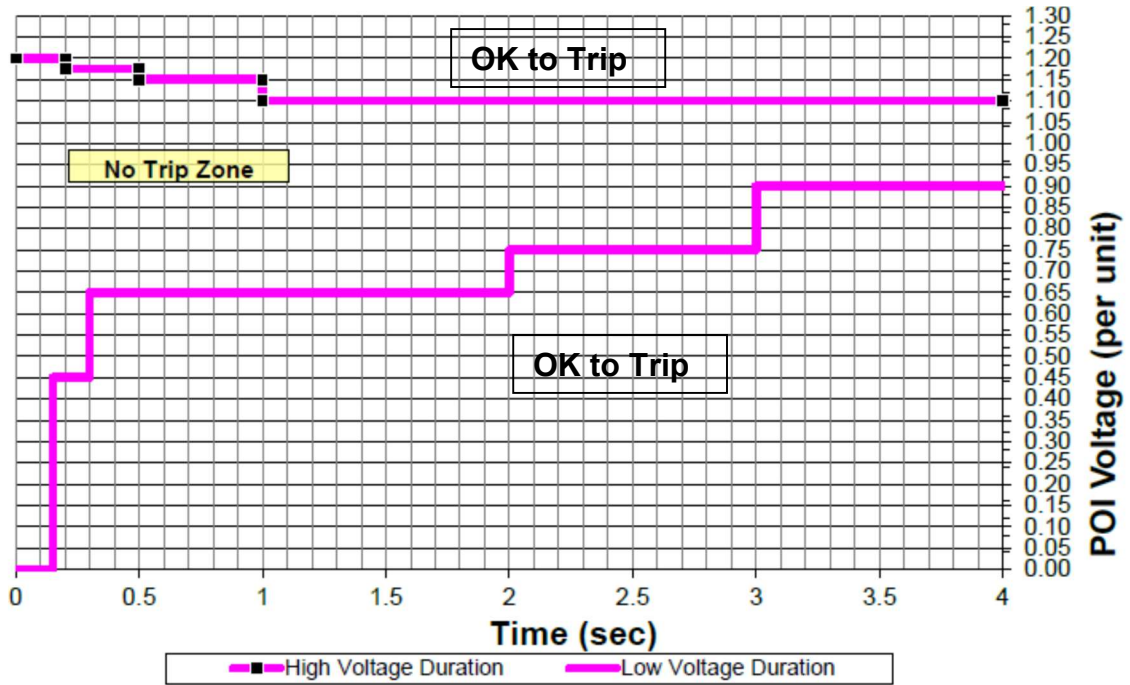

Figure 2
Generator Under / Over Voltage
Voltage Ride Through Time Duration Curve

Appendix 1 – Quick Reference Guide

Initial review

The developer should provide the following data for the initial protection review. This list is not all inclusive, the intent is to assist with highlighting major portions of the Transmission Interconnection Handbook (TIH) relating to transmission interconnections it is not a substitute for the content of the TIH.

Interconnection Facility Design

- **Proposed relays** – Relays should be redundant and on the approved relay list as specified in Tables G2.7 and G2.8 and DC powered from a station battery. Required relays are specified to ensure the facility is disconnected from the PG&E system during fault or abnormal conditions. If 3 phase microprocessor relays are used, they shall be redundant. The current and voltage input sources shall also be redundant. Exception is the voltage input source for generation protection relays.
- **Generator Synchronizing** - The application of synchronizing devices assures that a synchronous generator will parallel with the utility electric system without causing a disturbance to other customers and facilities (present and in the future) connected to the same system. It also attempts to assure that the generator itself will not be damaged due to an improper parallel action. This also includes interlocks to ensure there is not an unsupervised closing of a breaker into a generator. (Not required for Asynchronous generation that does not have stand-alone operating capability).
- **Interconnection Breaker Placement** – The breaker shall be placed in a location that minimizes the amount of 3rd party equipment protected by the PG&E system this also includes lightning arresters. Breaker must have DC trip coil tripped with DC supplied by a station battery. Tripping shall be via a dedicated lockout tripping relay. Automatic reclosing is not allowed.
- **Phase Rotation** – PG&E has ACB rotation, most of the industry uses ABC rotation, ensure this is taken into account in the facility design. (*One method is to roll B and C at the entrance to the substation*).
- **Interconnection XFMR** – Interconnection transformer must be Gnd Wye on HV side and Delta LV, or tertiary winding. Wye Gnd connection provides ground reference minimizing phase to ground overvoltage's, also providing ground source current to allowing ground fault detection to operate.
- **Station Battery** – Shall be a wet-cell lead acid type and meet the requirements in Appendix T. The DC system shall have a DC undervoltage alarm.
- **Metering PT/CT's** – Shall be located on the non-PG&E side of the line disconnect switch. Metering PT/CT's are dedicated for revenue metering they shall not be connected to protective relays or other equipment. (Refer to Section G1.3 for generation metering requirements).

- **Telemetry** - The Generation Entity is responsible for acquiring or providing the communication medium (lines) for transmission of transfer trip signals, alarms/status points, and the telemetry data. Refer to Appendix F for specific requirements and monitoring alarm points.

Appendix 1 – Quick Reference Guide

Documentation Requirement

- **Single Line Drawing** – Showing interconnection to PG&E System and the generator.
- **Single Line Meter and Relay** – Showing CT/PT interconnections to relays and other required control elements.
- **DC schematic drawings** –Schematic drawings for the interconnection required relays and Circuit Breaker that are used to separate the facility from the PG&E system.
- **3 Line AC** – Showing relay CT/PT connections.
- **Interconnection XFMR Nameplate Data** – Manufacturer’s test data showing XFMR positive and zero sequence impedance, and MVA nameplate data.
- **Generator Nameplate Data** – Manufacturers test data showing generation impedance data, should include $X''d$, $X'd$, X_s , X_2 , and X_0 data (not applicable for Asynchronous inverter based generation). Nameplate MVA data. For inverter based generation provide maximum fault current or low voltage ride-through overcurrent capability if this value is greater.
- **Generation tie line data** – Line impedance and tower configuration data.
- **Proposed Relay Settings** – Check required relays for coordination with PG&E relays. For synchronous generation verify if generators can detect end of line faults and trip < 1.5 seconds.

The next three pages show several types of representative interconnections with typical relays required for the interconnection.

Appendix 1 – Quick Reference Guide

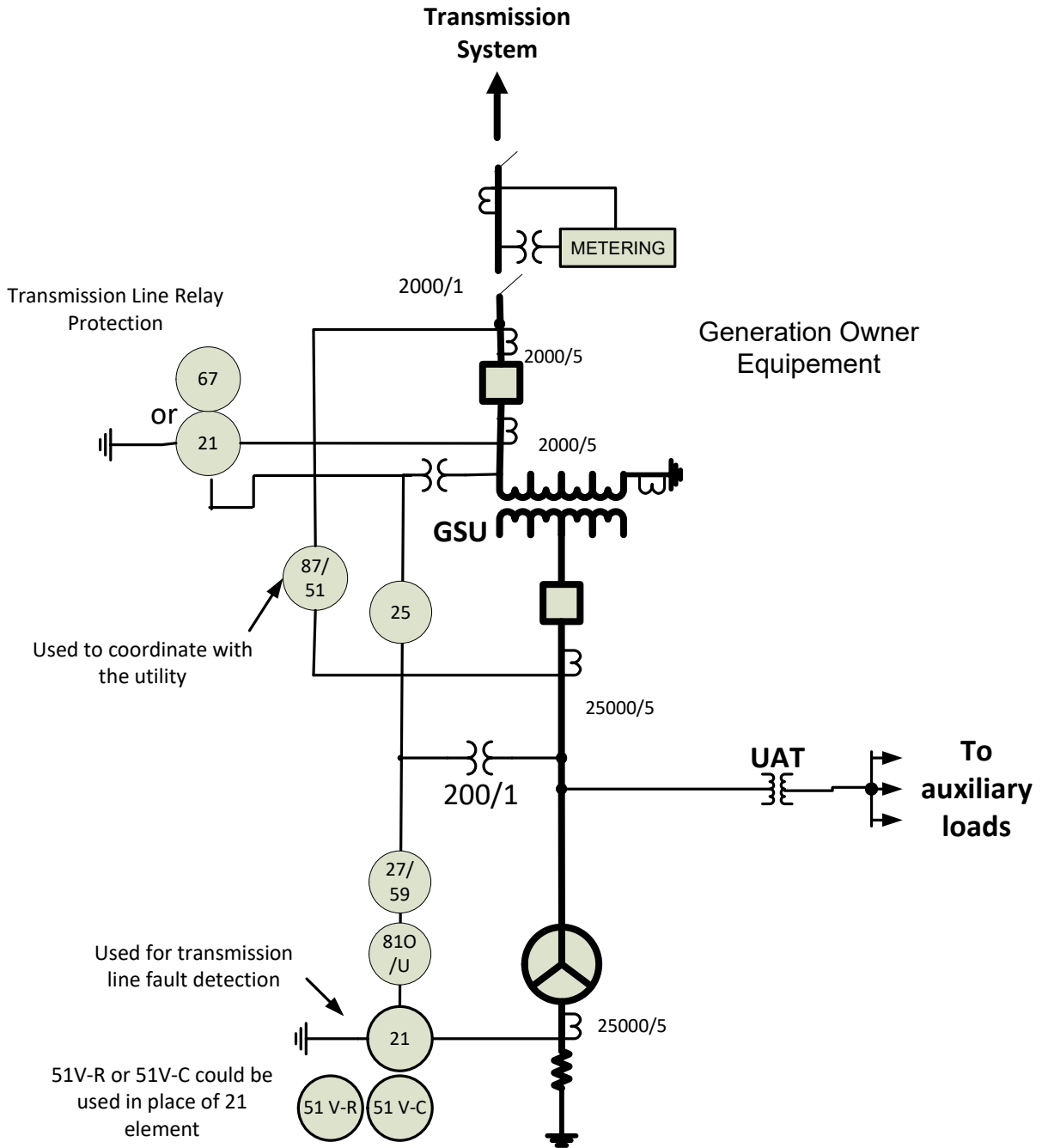
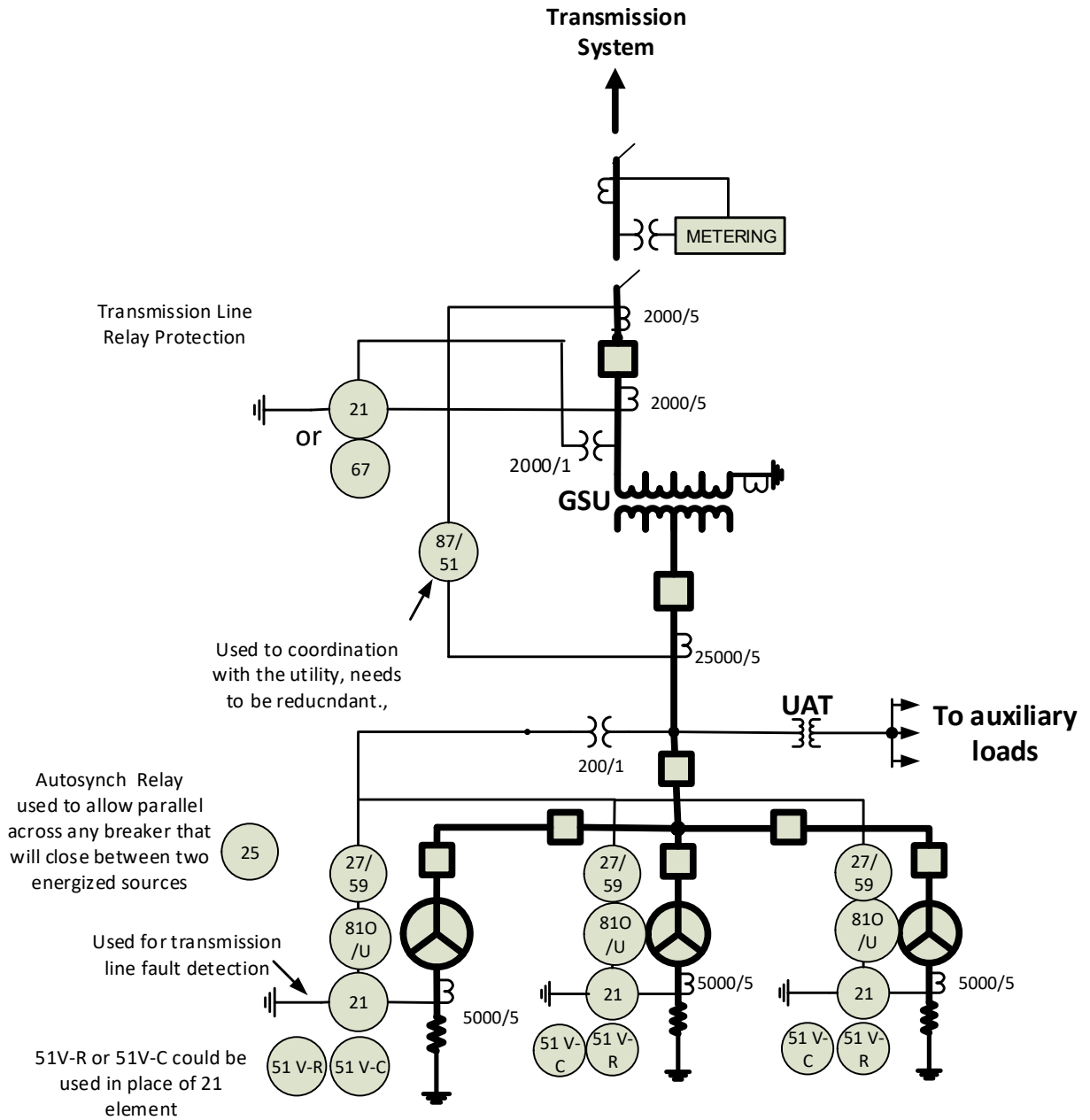

Figure A1-1

Single Synchronous Machine Installation

Appendix 1 – Quick Reference Guide



Typical Interconnection Relays for Multiple Generators

Figure A1-2

Multiple Generation Installations

Appendix 1 – Quick Reference Guide

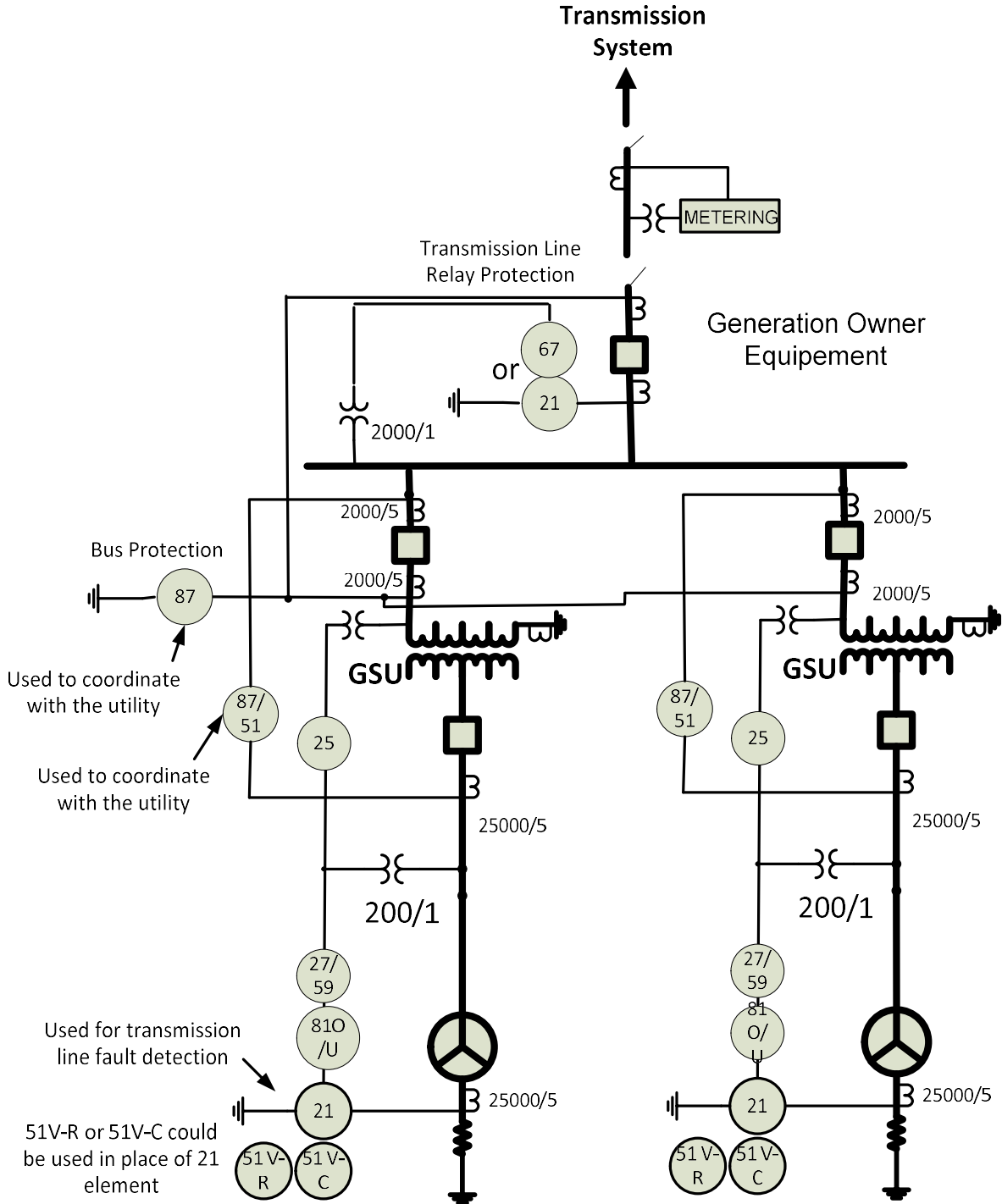

Figure A1-3

Multiple Generation Installation on HV Bus

Appendix 1 – Quick Reference Guide

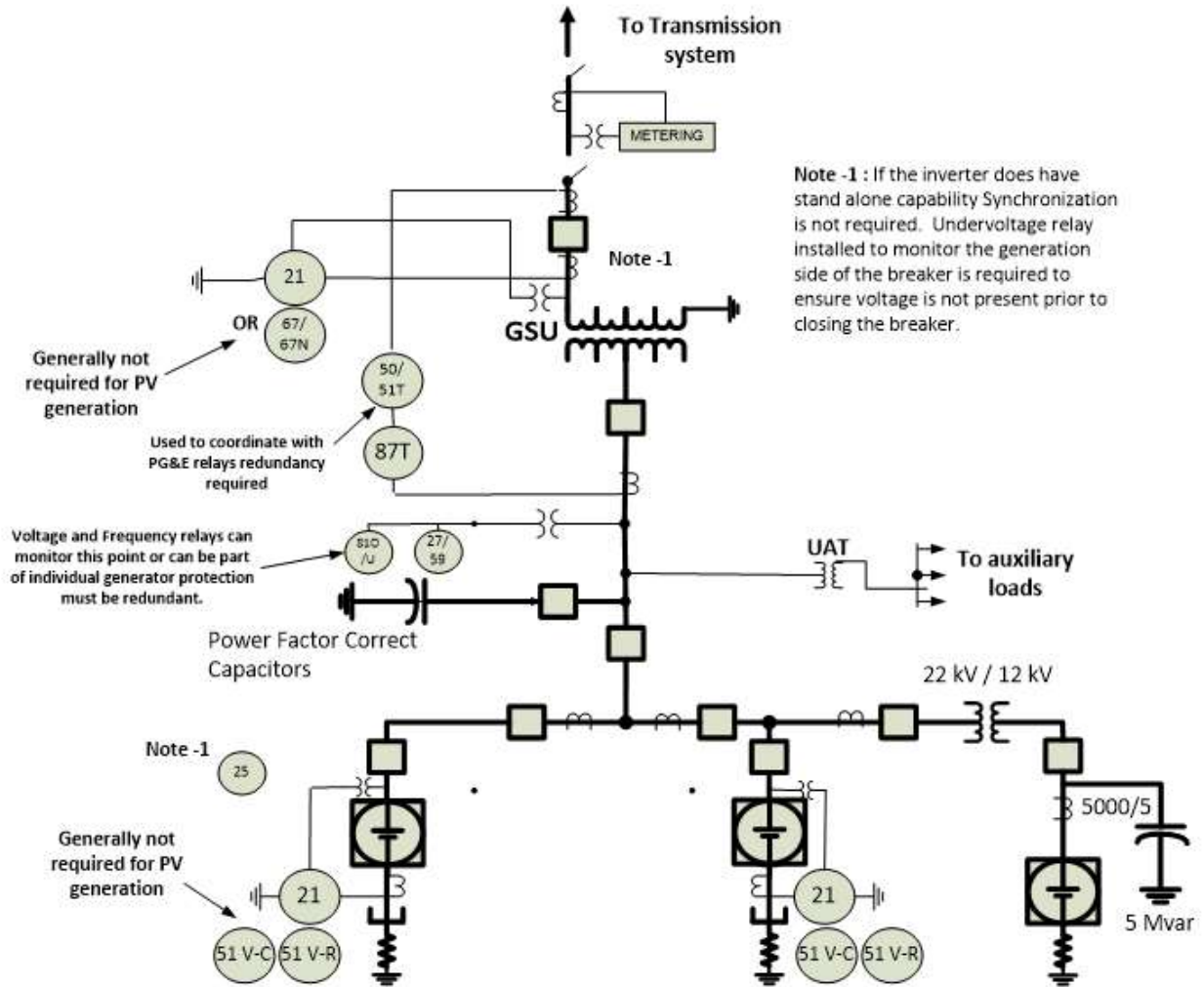

Figure A1-4

Asynchronous Generation Installations