



**PG&E METERED ELECTRICAL SERVICE TO ANTENNA AND
COMMUNICATION EQUIPMENT ON NON-PG&E
TELECOMMUNICATION OWNED POLES**

094679

Asset Type: Electric Distribution *D.W. Jantz* **Function:** Design, Estimating and Planning

Issued by: Daniel Jantz (DWJ7) **Date:** 03-25-22

Rev. 00#: This new document replaces bulletin TD-027911-B005, Rev. #02. For a description of the changes, see Page 9.

Purpose and Scope

This document illustrates PG&E's minimum design and construction requirements to receive metered overhead or underground electric service to antennas and communication equipment installed on telecommunication company (utility) owned wood poles.

References	Location	Document
Requirements for Customer-Owned Poles	OH: Services/Greenbook/EMWP	025055
Installation Details for Service to Pole-Mounted Communication Equipment	OH: Services/Greenbook	027911
Methods and Requirements for Installing Non-Residential Underground Electrical Services 0-600 Volts to Customer-Owned Facilities	UG-1: Services/Greenbook/EDM	063928
SmartPole Meter for Service to Pole-Mounted Communication Equipment	UG-1: Services/Greenbook	094675
PG&E Metered Electric Service to Antenna and Communication Equipment on Company Owned Steel Streetlight Poles	UG-1: Services/Greenbook	094677
PG&E Electric Service to Antenna and Communication Equipment on Municipality Owned Steel Streetlight Poles	UG-1: Services/Greenbook	094678

General Information

Failure to comply with these minimum requirements will result in disqualification. No variances will be reviewed or accepted.

1. All PG&E construction, clearances, and metering requirements must be met to receive electric service. This includes all applicable General Order (G.O.) 95 rules. See engineering [Document 027911](#) for detailed requirements.
2. A PG&E Absolving Service Agreement is required to be signed before PG&E will provide electric service. Contact the designated PG&E Service Planning office for an application for service and explanation of an Absolving Service Agreement.
3. All materials, except the PG&E service cables and meter, must be furnished and installed by the applicant. This includes the meter socket and disconnect switch combination enclosure.
4. The 3rd party owned pole must be from a PG&E approved supplier and meet the minimum specification requirements (e.g. class, height, supplier, loading, etc.). Ensure the pole is tall enough to meet the minimum vertical height requirements. See engineering [Document 025055](#) for the minimum pole setting depths and additional requirements.
5. Existing 3rd party poles must have pole loading and pole condition testing performed. Test results must be submitted for review and approval by PG&E.
6. The minimum horizontal clearance from a 3rd party owned pole, and any equipment installed on the pole to a PG&E pole and any equipment, crossarms, and wires on the pole, is 10 feet. See engineering [Document 025055](#) for specific pole clearance requirements.

**PG&E Metered Electrical Service to Antenna and
Communication Equipment on Non-PG&E
Telecommunication Owned Poles**

7. PG&E climbing space and access to the pole is always required. Unrestricted access is required for the installation and maintenance of the PG&E service and meter at all times
8. The PG&E meter and electric service, communication antenna and equipment receiving electric service must all be mounted on the same pole.
9. A second PG&E service is not allowed on the same pole.
10. The local Authority Having Jurisdiction (AHJ) of inspections for the city or county must provide approval of final inspection and meter release before PG&E will install a meter and energize the electric service.
11. A PG&E inspector or Trouble Man (T-Man) must inspect the installation to verify the requirements in this document have been met.
12. If changes are made to an existing antenna installation that requires the pole to be replaced, then all requirements in this document must be met.
13. Customer equipment shall be fused or otherwise protected against short-circuit currents. A fused switch or circuit breaker, approved for service entrances, is required. Communication type fuses and fuse holders are not satisfactory means of disconnecting the power source.
14. More than one communication provider's antenna and equipment are not allowed to receive service and be on the same pole.
15. Only one type of service connection (overhead or underground) is allowed on the same pole.

Underground Service

1. See overhead service Figure 1 on Page 5.
2. PG&E will provide either a 2-wire (1-hot, 1-neutral) 120-volt single-phase service or a 3-wire 1-phase 120/240-volt service from the PG&E specified splice box to the pole.

Note: In very limited locations if an existing PG&E 2-wire single-phase 240 volt secondary system is available the SmartPole meter may be connected. These locations are not common.
3. For a 3-wire 1-phase 120/240-volt service a SmartPole meter or PG&E approved meter panel is required. See the PG&E Electric and Gas Service Requirements Manual ([Greenbook](#)) for approved meter panels.
4. An underground service is required in areas designated as underground only.

Overhead Service

5. See overhead service Figure 2 on Page 6 and Figure 3 on Page 8.
6. The PG&E overhead service must only terminate at the pole with an antenna and communication equipment installed on it. The PG&E service must not be attached to non-PG&E poles that do not receive service.
7. Applicant cables must extend a minimum of 36 inches from the weatherhead. This will allow PG&E to create a drip loop when connecting the service cables.
8. The following clearances must be shown and described on drawings submitted to PG&E.
 - A. The vertical clearance, above grade, of the overhead electric service at the pole.
 - B. The vertical clearance, above grade, of the overhead electric service above any thoroughfares and walkable areas. Refer to Greenbook [Section 4.4.4. Vertical Clearance on Nonresidential Property](#).
 - C. The vertical clearances to all equipment attached on the pole that are above and below the PG&E overhead electric service.
 - D. Radial clearances from the overhead electric service to any structure, pole, and/or equipment along the path of the service wire to the distribution pole. Identify and label the type of structure or equipment, if any.

SmartPole Metering

9. A PG&E SmartPole Meter and enclosure are required for these installations. Refer to PG&E [Document 094675](#) listed on Page 1, for specific requirements.

Note: Other designs for the placement of the metering equipment not in compliance with the requirements described in this document are **not** being accepted.

10. The meter and enclosure must be installed on the pole at a minimum of 7 feet to a maximum of 8 feet above grade, as measured from the bottom of the enclosure, and not exposed to vehicular traffic.
11. The customer load must not exceed 16 amps for non-transformer rated SmartPole meters.
12. The customer load must not exceed 68 amps for transformer rated SmartPole meters.
13. The SmartPole meter must be mounted on the same pole as the service, antenna, and communication equipment. **Remote metering is not allowed.**
14. PG&E Meters must **not** be installed on poles that are in traffic medians or traffic islands where vehicle thoroughfares are on more than one side of the pole. A different pole or pole location must be selected for the meter, service, antenna, and communication equipment.
15. When pole metering is unacceptable because it does not meet the PG&E criteria and requirements, the alternative method is to install an approved pad-mounted metering pedestal served from a PG&E underground service. Some examples of unacceptable situations include locations:
- Where access to the meter is impaired.
 - Where meters may be subject to obvious traffic hazards or unsafe working conditions.
 - Where hillside pole locations render metering unsafe.
16. The metering provision contained herein is an exception to the Greenbook requirement and is designed primarily for antenna and communication type equipment requiring metering.

Disconnect Switch

17. A lockable disconnect switch must be installed and meet all of the following requirements below.
18. Refer to [Document 094675](#) for installation requirements of the switch.
19. The disconnect switch must de-energize all customer equipment (ac and dc) on the pole, including antennas, power supplies, radios, as well as any types of backup power sources.
20. The switch must not de-energize (turn off) the PG&E Smart Meter.
21. The disconnect switch must be readily accessible at all times. The switch will be used as part of the normal or emergency shutdown protocols required in California Public Utility Commission (CPUC) General Order 95, Rule 94.
22. Signage must be attached to the switch identifying what equipment it will de-energize.
23. If installing an individual disconnect switch, instead of the meter & disconnect combination enclosure, it must be attached externally on the pole less than 10 feet above grade and more than 4 feet above grade, as measured to the bottom of the switch enclosure.
- Note: The local authority having jurisdiction of inspection may have minimum and maximum height requirements that must also comply besides the PG&E requirements.
24. The switch may **not** be installed in a subsurface enclosure, or in a remote location away from the pole.
25. The disconnect switch must have locking provisions, to lock the switch in the off (de-energized) position, and that accept a padlock having a 5/16-inch lock shaft. The locking provisions must be available to PG&E at all times. A double hasp locking method is allowed.

Signage

26. Poles must have signage that describes the RF exposure and Minimum Approach Distance (MAD) for each installation. See engineering [Document 027911](#) for detailed requirements.
27. Sites must be signed according to FCC guidelines.
28. Antennas and communication equipment installed on poles must have an ownership label with a contact number, and site identification information. Poles shall be marked for each equipment installation. The sign shall contain the following information and placement.
 - A. Name / identification of the antenna operator
 - B. A 24-hour contact number of antenna operator for emergency notification or other information
 - C. Unique identifier of the antenna installation
 - D. Indication that the antennas RF output is in compliance with the FCC General Population (G.P.) uncontrolled exposure limits or if the antenna exceeds those limits indication of the minimum approach distance.
 - E. Located above the SmartPole Meter and not greater than 15 feet above grade.

Design Drawings

29. Detailed drawings must be submitted showing, but not limited to, the following items.
 - A. A Single Line Drawing showing the wire sequence to all PG&E and customer equipment.
 - B. Pole class, supplier, and heights above grade to all equipment and the top of pole.
 - C. Radial clearances, above and below the PG&E overhead electric service attached at the pole, to all other equipment attached to the pole. Clearances to equipment attached to and supported by communication cables but not attached to the pole must also be shown.
 - D. Radial clearances from the overhead electric service to any structure, pole, and/or equipment along the path of the service wire from pole to pole. Identify and label the type of structure or equipment, if any.
 - E. Vertical height of the overhead electric service above grade at the pole as well as above any thoroughfares and walkable areas.
 - F. Show and state if a SmartPole meter enclosure or meter panel will be installed. The quadrant position on the pole and radial clearances to other equipment on the pole. The height of the metering equipment above grade. If a meter panel is being installed provide the manufacturer, model number and ensure the meter panel has test bypass facilities.
 - G. Show the radial clearances from the closest part of the metering equipment enclosure to all thoroughfares, private streets or roads, driveways, structures, trees and large vegetation, gates, or other obstructions. Indicate if the thoroughfare, street, or road has a curb, rolled curb, ramp(s), or no curb
 - H. Climbing space(s) from grade to the PG&E service location.
 - I. Riser(s) location for any quadrant, when applicable.
 - J. Disconnect switch location, height above grade, and radial clearance from metering equipment.
 - K. Location and identification of all signage.

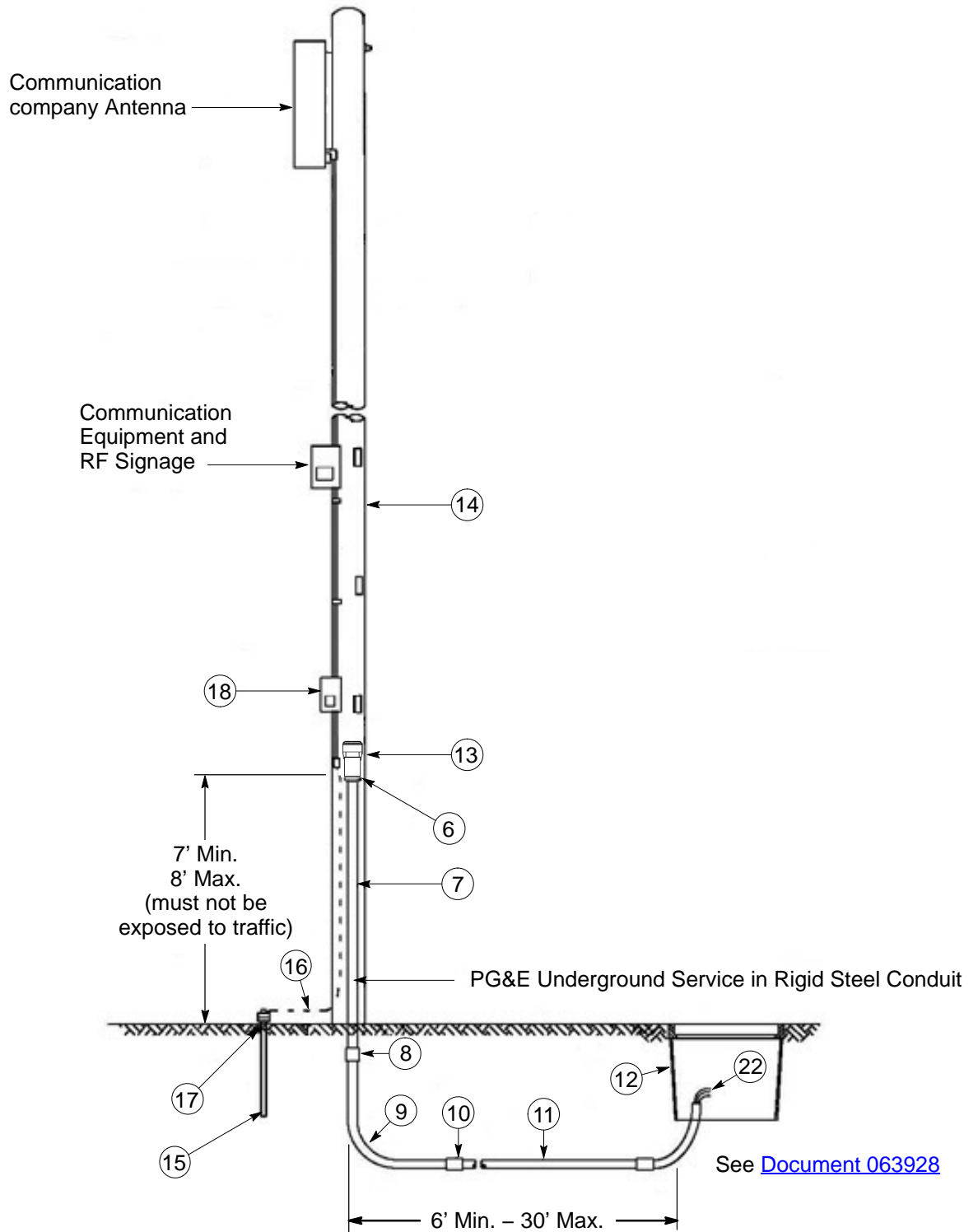
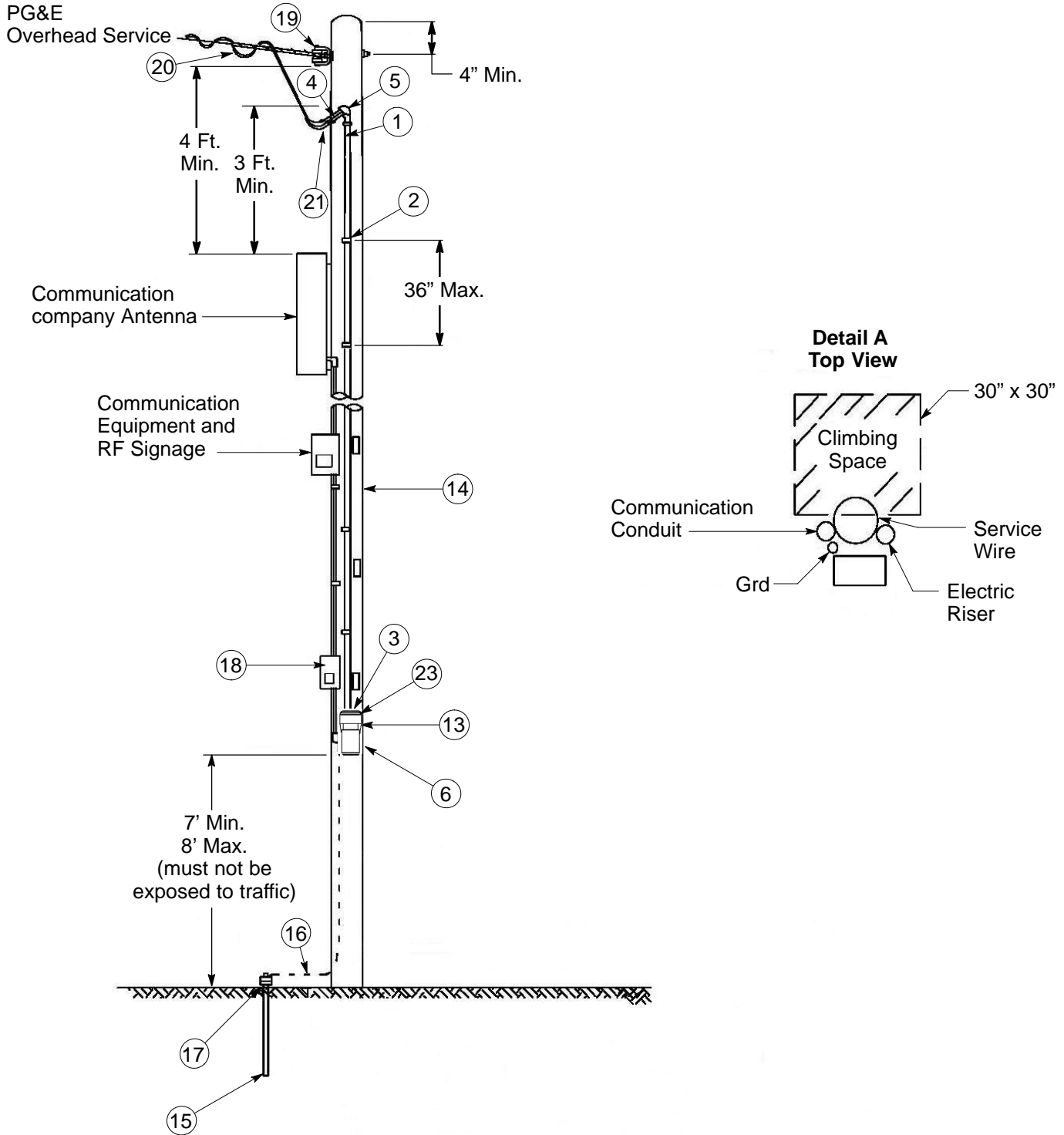

Figure 1
Underground Pole-Metered Service Connection to
Communication Equipment and Antenna

**PG&E Metered Electrical Service to Antenna and
 Communication Equipment on Non-PG&E
 Telecommunication Owned Poles**



**Figure 2
 Overhead Service Connection to Communication
 Equipment and Antenna Below Pole Top**

Table 1 Bill Of Materials To Be Furnished And Installed By 3rd Party Communication Company

Item	Description
For Overhead Service	
1	Conduit, Rigid, PVC, Schedule 80, (size as required) ¹
2	Pipe Straps, Galvanized, Heavy Duty
3	Conduit Fittings, PVC, (as required)
4	Wire, 600 V, (size as required)
5	Service Weather Head, PVC
For Underground Service	
6	Conduit Fittings, Rigid Steel, (as required)
7	Conduit, Riser, Galvanized Rigid Steel, Continuous without Couplings
8	Plastic-to-Steel Adapter/Coupling, (installed below grade)
9	Conduit, Bend, PVC, Continuous without Couplings
10	PVC Conduit, Coupling
11	Service Conduit, (as required by 063928)
12	PG&E Underground Splice Box, (size as required by 028028) ²
For Overhead or Underground Service	
13	SmartPole Meter Enclosure (094675)
14	Wood Pole (From PG&E Approved Supplier)
15	Ground Rod
16	Ground Wire, Copper, Bare
17	Ground Clamp (as required)
18	Disconnect Switch

¹ Use Schedule 80 for 1-1/2" or smaller, or Schedule 40 for 2".

² The pull box is required to be installed.

Table 2 Table 2 Bill Of Material To Be Furnished And Installed By PG&E

Item	Description	Document
19	Spool and Clevis, (when required)	022439
20	Service Wires, Overhead (when required) ¹	059626
21	Connector, Compression or Wedge, Overhead Service, (when required)	041010
22	Service Conductors, Underground (when required) ¹	039955
23	SmartPole Meter	094675

¹ 3-Wire for standard Meter Panel ([Greenbook](#)) and 2-Wire for SmartPole Meter Enclosure.

**PG&E Metered Electrical Service to Antenna and
 Communication Equipment on Non-PG&E
 Telecommunication Owned Poles**

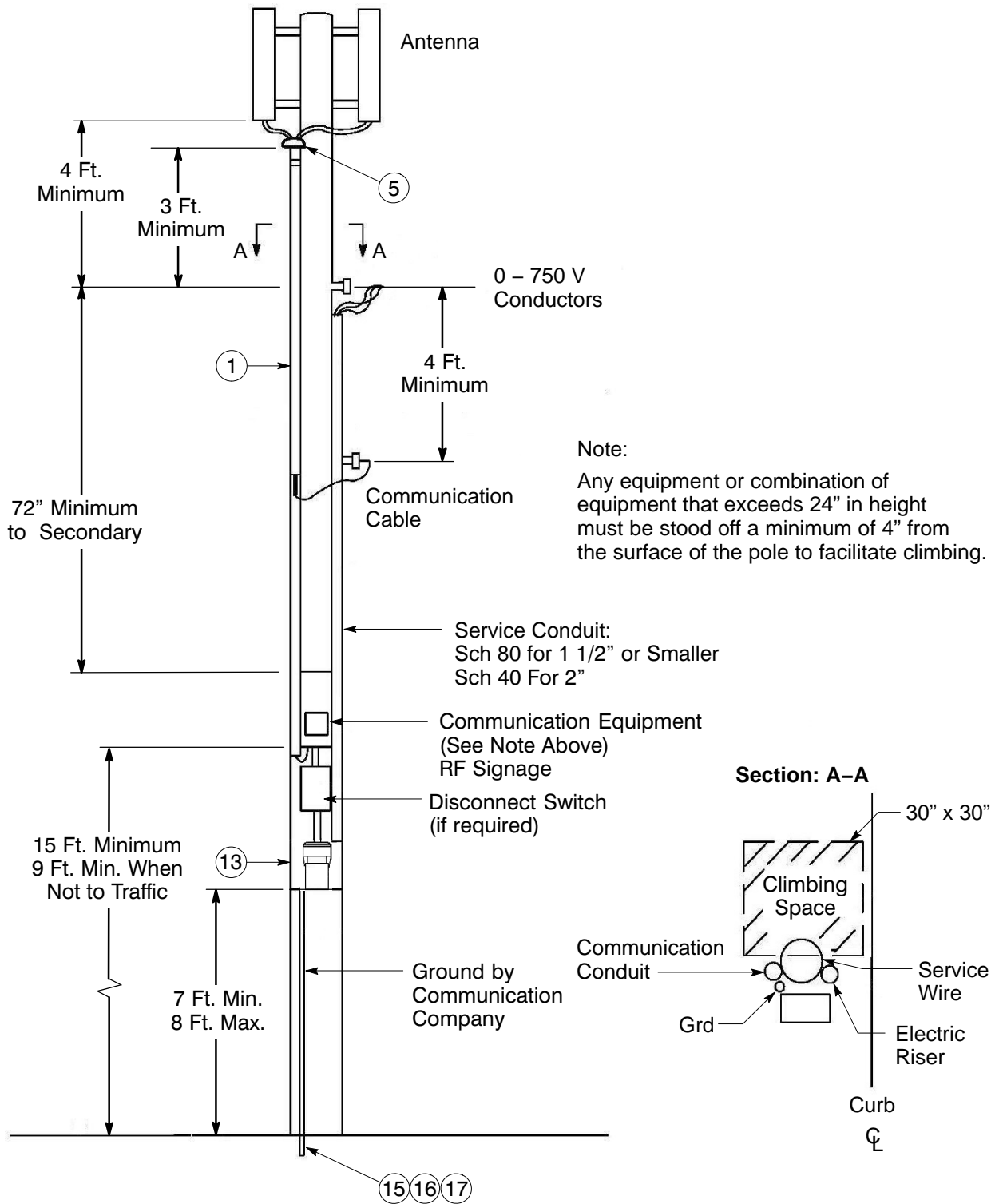

**Figure 3
 Overhead Service Connection to Antenna at Pole Top**

Revision Notes

Revision 00 has the following changes:

1. Converted Bulletin TD-027911-B005 to this new numbered engineering document.
2. Updated requirements throughout.
3. Added Figure 2 on Page 6.